

PalArch's Journal of Archaeology of Egypt / Egyptology

RELATIONSHIP BETWEEN CHARACTERISTICS AND UNIVERSITY INTENTION: A CASE STUDY OF STUDENTS IN VIETNAM

Nguyen Nghi Thanh¹, Le Thi Van Anh², Ho Duc Hiep³, Phuong Huu Tung⁴

^{1,2}Faculty of Political Science, Hanoi University of Home Affairs, Vietnam.

³Hanoi University of Home Affairs - Ho Chi Minh Campus, Ho Chi Minh City, Vietnam

⁴Faculty of Human Resource Management, Ha Noi University of Home Affairs, Vietnam

Corresponding Author: Email: phuonghuutung@gmail.com

Nguyen Nghi Thanh, Le Thi Van Anh, Ho Duc Hiep, Phuong Huu Tung. Relationship Between Characteristics and University Intention: A Case Study of Students in Vietnam -- PalArch's Journal of Archaeology of Egypt/Egyptology 18(18), 44-69. ISSN 1567-214x

Keywords: Big Five; Intention; Study Abroad, University; Student; Vietnam.

ABSTRACT:

Vietnamese students studying in universities worldwide in recent years have received the attention of parents, students and the whole society. This study aims to enrich the research literature, and this study explores the relationship between personality and intention to study at the university of Vietnamese students. This study was conducted through a cross-sectional survey using a targeted sampling technique of 400 high school students taking the exit exam. The SEM model is used to test the hypotheses, and the results show that: students have five personality types and all have a positive and significant impact on the intention to study abroad. In which personality neuroticism and extraversion act with large regression weights. This study provides valuable data for education policymakers, universities, businesses and study abroad consulting organizations.

INTRODUCTION

Since 2018, Vietnam has become one of the top countries to send students abroad (Ashwill, 2018). Studies show that about 90% of Vietnamese students study abroad independently with financial support from their families. Vietnamese students contribute a lot to the country and territory they choose to study. In the 2016-2017 school year, the amount spent studying in the US amounted to 818 million USD (Ashwill, 2018, Trang, 2018). This fact requires research to explore the factors affecting the study abroad of Vietnamese students.

Few studies have directly investigated the reasons why Vietnamese students want to pursue their studies abroad. Nguyen (2013) argues that the growing demand for skilled labour, the low quality of higher education, globalization and regionalization, the government's commitment to sending students abroad. Vietnamese families are eager to improve their children's career prospects, and many international educational institutions have contributed to promoting the value of having an international educational experience (Bodewig, Badiani-Magnusson), & Macdonald, 2014). Over the past two decades, the country has experienced rapid socioeconomic growth (Leung, 2010; Shultz, 2012; World Bank, 2015). As a result, higher education has been expanded and reformed to produce more graduates with the right qualifications and capabilities to meet the needs in the labour market and achieve the goals socioeconomic targets set by the government (Bodewig, Badiani- Magnusson, & Macdonald, 2014; World Bank, 2008). The university system does not seem to be responding to the more considerable demand for higher education (Harman, Hayden, & Nghi 2010; Chi, 2013). There are growing concerns about the quality of the higher education system in Vietnam (Harman, Hayden & Nghi, 2010; Chi, 2013; Welch, 2013). Because employers are not satisfied with the quality of graduates from Vietnamese universities, they are intended to favour graduates from foreign institutions (Nghia, 2011). The commitment of the Government of Vietnam to sending Vietnamese students abroad and the presence of many international educational groups or organizations have contributed to promoting the value of the international educational experience (Chi, 2013; Sirat). , Azman & Bakar, 2014). As a result, there has been an increase in Vietnamese students sent abroad to obtain international education for better career prospects and to achieve personal growth (Clark, 2013; Chi, 2013).). The number of Vietnamese students going abroad to study international education programs has continuously increased. Real-life experience and studying in a host country is a rewarding learning experience for Vietnamese students (Doherty & Evershed, 2018; Kritz, 2012).

Currently, the research exploring the factors affecting the intention to study abroad mainly approaches individual students. Specifically, factors originating from the host country's culture, quality of education and better life include the attractiveness factor of the host country's culture (Chen, 2007; Chung, Holdsworth, & Li dan Fam, 2009; Counsell, 2011; Lee dan Morrish, 2011). factors of better living abroad (Chen, 2007; Chung, Holdsworth & Li dan Fam, 2009), factors that have the opportunity to immigrate to the host country (Mazzarol & Soutar, 2002; Bodycott, 2009); factor enjoys good university facilities (Price, Matzdorf, Smith & Agahi, 2003; Bodycott, 2009); factor receiving better international experience and quality of higher education abroad (Bodycott, 2009; Mazzarol & Soutar, 2002; Chen & Zimitat, 2006; Counsell, 2011). factors of language access and opportunities to learn English as a non-native and second language (Chen & Zimitat, 2006; Engelke, 2008; Bodycott, 2009; Eder, Smith & Pitts, 2010); Counsell, 2011). Reputation factor for the quality of universities abroad (Mazzarol & Soutar, 2002; Soutar & Turner, 2002; Cubillo, Sánchez & Cerviño, 2006; Maringe, 2006; Bodycott, 2009; Petruzzellis & Romanazzi, 2010); low cost of living factor (Landes, 2008; Parafianowicz, 2009; Petruzzellis & Romanazzi, 2010).

The university and government policy factors include university financial support for international students (Cheung, Yuen, & Cheng, 2011; Pimpa, 2003; Marnge, 2006; Bodycott, 2009; Petruzzellis & Romanazzi, 2010). Factor in the ease and convenience of obtaining an entry visa (Cubillo, Sánchez & Cerviño, 2006; Marnge & Carter, 2007); factors are well secured (Chen & Zimitat, 2006; Marinege & Carter, 2007; Chen, 2007; Bodycott, 2009).

In addition, researchers have also explored other factors, such as the recognition of degrees from prestigious universities (Mazzarol & Soutar, 2002; Soutar & Turner, 2002; Marnge, 2006). Geographic distance between home and university (Mazzarol & Soutar, 2002; Bodycott, 2009; Eder, Smith & Pitts, 2010). Influence, recommendations, and support from family, friends, and academics (Mazzarol & Soutar, 2002; Pimpa, 2002; Chen, 2007; Marnge & Carter, 2007; Bodycott, 2009; Lee & Morrish, 2011).

There is still a lack of studies exploring the relationship between personality and intention to study abroad. This article fills in this absence by examining the relationship between the five personality traits and the intention to study abroad.

LITERATURE REVIEW

Intention To Study Abroad:

There are many approaches to studying intention to study abroad. Planned behaviourists argue that behavioural intentions are determined by attitudes toward the behaviour, subjective norms, and perceived behavioural control (Ajzen & Madden, 1986; Ajzen, 1991). They are studying the factors affecting Vietnamese students' intention to study abroad, mainly discovered the impact of pull factors and push factors (Nghia, 2010). Pull factors include: foreign cultural experience; gain international experience; establish relationships with international friends; improve foreign language ability; improve international employment opportunities; pursue foreign educational values (Nghia, 2019). Push factors include university competition in Vietnam; not having the desired university program available; avoid theoretical problems in Vietnamese education; was decided by the family to study abroad; pursue immigration opportunities; The quality of education in Vietnam is not high (Nghia, 2019). Other studies that did not use the push-pull model have reached similar conclusions and revealed that international students' decisions to study abroad could be influenced by family, teachers, and economic issues social, political and cultural differences in both home and host countries (Allison & Ma, 2016; Liu & Morgan, 2016; Nguyen, 2013; Spinks, 2016). Studies have found that real-life experience and studying in a host country is a rewarding learning experience for many students. As a result, Vietnamese students going abroad to pursue international education have continuously increased in recent decades, especially in the United States, United Kingdom and Australia (Doherty & Evershed, 2018; Kritz, 2012).). They come to the country mainly to study and experience a new culture and not necessarily pursue immigration opportunities (Tran & Vu, 2016).

Push factors include: not available the desired program; entrance exams to Vietnamese universities; poor quality of education in Vietnam; avoid bad practices in Vietnamese education; seek immigration opportunities; was asked by their family to study abroad. Pull factors include: pursuing foreign educational values; gain international experience; a foreign cultural experience; establish relationships with international friends; improve foreign language ability; improve international employment opportunities (Nghia, 2015).

In addition, studies have also found that the intention to study abroad is influenced by different demographic factors (Nghia, 2015; Hemsley Brown & Oplatka, 2015). There is currently a lack of empirical research on the relationship between personality traits to study abroad. Whether the intention to study abroad is affected by personality traits or not. The article will experimentally explore this.

Big Five Model

Personality is an individual psychological attitude that determines how individual acts and reacts to the environment around him. Personality is expressed in the individual's attitude system and in the will qualities of man. In other words, an individual's personality is a combination of psychological characteristics by which we can distinguish this individual from others. Several factors affect the formation of an individual's personality: congenital, genetic, nurturing, learning, socio-cultural environment, circumstances, situations. There are many models of personality research. The Big Five is an essential tool for assessing different aspects of a person's personality (Gerber et al., 2010). Psychologists suggest that personality can be summarized by five characteristics (John, Naumann & Soto, 2008; McCrae & Costa, 2008).

The five core traits are extroversion, agreeableness, openness, conscientiousness, and sensitivity (Gerber et al., 2010). The Big Five model is applied to many different research fields such as predicting general prejudice (Ekehammar & Akrami, 2003; Sibley & Duckitt, 2008), racism (Jackson & Poulsen, 2005; Silvestri & Richardson, 2001), attitudes towards immigrants (Akrami, Ekehammar & Bergh, 2011), political ideology (Carney et al., 2008; Jost, Nosek, & Gosling, 2008; Jost, 2006), politics (Hibbing, Ritchie, & Anderson 2011; Gerber et al., 2011; Mattila et al., 2011; Mondak, Halperin, 2008; Mondak, 2010; Mondak & Halperin, 2008).

The five personality traits of individuals manifest in different cultures. Therefore, individuals must be placed in specific situations to understand their personality (Allik & McCrae, 2004; Heine & Buchtel, 2009; Schmitt et al., 2007; Denissen & Penke, 2008, Mischel & Shoda, 1995; Canli, 2008). The five personality traits provide a clear explanation of social attitudes and behaviour because it is internal to the individual and, to a large extent, predates adult social experiences: it is systematic large genetic numbers (Medland & HHri, 2009; Yamagata et al., 2006). Personality stabilizes in adulthood (Caspi & Roberts, 2001; Hampson & Goldberg, 2006; Terracciano, McCrae & Costa, 2010). Personality traits are related to economic, social, and

political attitudes and behaviours (Gerber et al., Gerber et al., 2010, Gerber et al., 2011, Mondak, 2010; Mondak & Halperin, 2008; Mondak et al., 2010).

In addition, five major personality factors have been studied to compare the suitability and decision of an individual's career choice (Barrick & Mount, 1991, Barrick, Mount, & Judge, 2001). In the civil field, individuals with a high self-control index often adhere to the principles and standards of the organization, work hard and persevere in work plans. On the other hand, individuals with low self-esteem often show disorganized, quit, irresponsible, careless, negligent and impulsive behaviour at work (Jin, Watkins, & Yuen 2009).

Chart 1. The Big Five Personality Dimensions

Trait	Characteristics associated with the trait
Extroversion - Intraversion	Sociable, gregarious (vs. reserved), assertive, talkative, active
Neuroticism - Emotional Stability	Anxious/nervous (vs. relaxed), depressed, angry, embarrassed, emotional, worried, insecure
Agreeableness - Antagonism	Courteous/considerate/kind (vs. rude), flexible, trusting, good-natured, cooperative, forgiving, soft-hearted, tolerant
Conscientiousness - Lack of Direction	Dependability: careful, thorough, responsible, organized, planful Volitional aspects: Hardworking (vs. lazy), achievement-oriented/effective, persevering
Open to Experience - Closed to Experience	Imaginative, cultured, curious/eager for knowledge, original, broad-minded, intelligent, artistically sensitive

(*Source: Barrick and Mount (1991)*)

Openness: People with an open personality focus on imagination and insight. People with these characteristics are often inquisitive about everything around them. They are genuinely creative, always ready to learn new things and focused on overcoming challenges (John, Naumann & Soto, 2008; McCrae & Costa, 2008; Barrick, Mount 1991). People who score high on this trait tend to be exploratory and creative, while those with low scores tend to work traditionally and often shy away from absorbing new ideas.

Conscientiousness: People with a conscientious personality are thoughtful, control their anger, and have explicit goals. If they are dedicated, they are usually thoughtful, attentive to details, well-prepared, prioritized on essential tasks, and excited about their schedule. In contrast, individuals with low conscientiousness often dislike following stereotypes and schedules, do not care about everything, are somewhat sloppy, and are somewhat indiscriminate

(John, Naumann, & Soto 2008; McCrae & Costa, 2008; Barrick & Mountain, 1991).

Extraversion: An extrovert who is very relaxed and energetic when socializing, enjoys being the center of attention, is a conversation starter, and feels active when around people. Introverts, on the other hand, tend to stay away from crowded places, feel exhausted when they have to socialize too much, have trouble initiating conversations, and often think things through carefully before talking (John, Naumann & Soto, 2008; McCrae & Costa, 2008; Barrick & Mount 1991).

Agreeableness: Trust, altruism, kindness, and empathy are the essential characteristics of agreeableness. People with this personality are usually friendly, cooperative, and enthusiastic. However, people who are not agreeable are often unapproachable and have little interest in other people's problems (John, Naumann, & Soto 2008; McCrae & Costa, 2008; Barrick & Mount, 1991).

Neuroticism: Also known as a measure of emotional stability. Sensitive people tend to be sad, moody, and emotionally unstable. People with a high index of this personality often experience emotional instability and negative emotions (John, Naumann, & Soto 2008; McCrae & Costa, 2008; Barrick & Mountain, 1991).

Studies on personality traits related to intention to study abroad, choosing a study abroad location: Clavel (2015); Eder & Smith, & Pitts (2010) find that migrants choose to study in a country with an "interesting" culture and utterly different from their own in order to gain valuable life experience. An enjoyable cultural experience is one of the essential factors international students choose to study abroad (Eder, Smith, & Pitts 2010). Language-conscious migration is also part of the culture, and, naturally, international students will choose to study in a country where they can communicate in the host country's language, as it is a prerequisite for their studies and social life in the host country (Bourke, 2000; McCarthy, Sen & Fox Garrity, 2012). Similarly, emigration personality concerning the desire to experience the country's reputation and the university has a significant impact on attracting international students to apply. Factors related to an institution's reputation may include the general institutional image, the quality of the faculty, interactions with faculty and staff, availability of the desired program, support services, language of instruction, facilities and infrastructure, flexible planning options, and financial aid (Hemsley-Brown, 2012; Hemsley-Brown & Oplatka, 2015; Mazarol & Soutar, 2002; Price) et al., 2003). Migrant, open-minded people put career at the center of a priority (Frieze et al., 2004; Misra, Ghosh, & Kanungo, 1990). Personality traits correlate with attitudes towards study abroad immigrants (McCarthy et al., 2012).

Based on a summary of studies on intention to study at university and migratory personality, this study proposes the following hypotheses:

H1. Extraversion personality has a positive and significant effect on the intention to study abroad.

H2. Personality Neuroticism has a positive and significant impact on intention to study abroad.

H3. Agreeableness has a positive and significant effect on the intention to study abroad.

H4. Conscientiousness personality has a positive and significant impact on intention to study abroad.

H5. Openness personality has a positive and significant impact on intention to study abroad.

MATERIALS AND METHODS

Variables And Measures

The study used measures of 44-item inventory that measures an individual on the Big Five Factors (dimensions) of personality (Goldberg, 1993). Each of the factors is then further divided into personality faces (chart 1). Each item is measured on a 5-point Likert scale (Disagree strongly =1; Disagree a little = 2; Neither agree nor disagree =3; Agree a little = 4; Agree Strongly =5). From the collected data, reverse-scored items will be transformed before putting the data into the analysis of the next steps.

Based on consultation with education experts, the month of measuring intention to study abroad was built with six items. Each item is measured on a 5-point Likert scale (Disagree strongly =1; Disagree a little = 2 ; Neither agree nor disagree =3 ; Agree a little = 4; Agree Strongly =5) (chart 1).

Chart 2. Items in the questionnaire

Code		Disagree strongly =1; Disagree a little = 2 ;Neither agree nor disagree =3 ; Agree a little = 4; Agree Strongly =5				
Extraversion	Extraversion					
Extraversion1	Is talkative	1	2	3	4	5
Extraversion2	Is reserved (R)	1	2	3	4	5
Extraversion3	Is full of energy	1	2	3	4	5
Extraversion4	Generates a lot of enthusiasm	1	2	3	4	5
Extraversion5	Is generally trusting (R)	1	2	3	4	5
Extraversion6	Has an assertive personality	1	2	3	4	5
Extraversion7	Is outgoing, sociable	1	2	3	4	5
Extraversion8	Is sometimes shy, inhibited (R)	1	2	3	4	5
Agreeableness	Agreeableness					
Agreeableness1	Tends to find fault with others (R)	1	2	3	4	5

Agreeableness2	Is helpful and unselfish with others	1	2	3	4	5
Agreeableness3	Starts quarrels with others (R)	1	2	3	4	5
Agreeableness4	Has a forgiving nature	1	2	3	4	5
Agreeableness5	Is generally trusting	1	2	3	4	5
Agreeableness6	Can be cold and aloof	1	2	3	4	5
Agreeableness7	Is considerate and kind to almost everyone	1	2	3	4	5
Agreeableness8	Is sometimes rude to others (R)	1	2	3	4	5
Agreeableness9	Likes to cooperate with others					
Conscientiousness	Conscientiousness					
Conscientiousness1	Does a thorough job	1	2	3	4	5
Conscientiousness2	Can be somewhat careless (R)	1	2	3	4	5
Conscientiousness3	Is a reliable worker	1	2	3	4	5
Conscientiousness4	Tends to be disorganized (R)	1	2	3	4	5
Conscientiousness5	Tends to be lazy (R)	1	2	3	4	5
Conscientiousness6	Perseveres until the task is finished	1	2	3	4	5
Conscientiousness7	Does things efficiently	1	2	3	4	5
Conscientiousness8	Makes plans and follows through with them	1	2	3	4	5
Conscientiousness9	Is easily distracted (R)					
Neuroticism	Neuroticism					
Neuroticism1	Is depressed, blue	1	2	3	4	5
Neuroticism2	Is relaxed, handles stress well	1	2	3	4	5
Neuroticism3	Can be tense	1	2	3	4	5
Neuroticism4	Worries a lot	1	2	3	4	5
Neuroticism5	Is emotionally stable, not easily upset (R)	1	2	3	4	5
Neuroticism6	Can be moody	1	2	3	4	5
Neuroticism7	Remains calm in tense situations (R)	1	2	3	4	5
Neuroticism8	Gets nervous easily	1	2	3	4	5
Openess	Openness					
Openess1	Is original, comes up with new ideas	1	2	3	4	5
Openess2	Is curious about many different things	1	2	3	4	5
Openess3	Is ingenious, a deep thinker	1	2	3	4	5
Openess4	Has an active imagination	1	2	3	4	5

Openess5	Is inventive	1	2	3	4	5
Openess6	Values artistic, aesthetic experiences	1	2	3	4	5
Openess7	Prefers work that is routine (R)	1	2	3	4	5
Openess8	Likes to reflect, play with ideas	1	2	3	4	5
Openess9	Has few artistic interests (R)	1	2	3	4	5
Openess10	Is sophisticated in art, music, or literature	1	2	3	4	5
Intent	My intention to studying abroad					
Intent1	I have considered going to study abroad	1	2	3	4	5
Intent2	I am very interested in studying abroad	1	2	3	4	5
Intent3	I expected to study abroad	1	2	3	4	5
Intent4	I try to study abroad in the future	1	2	3	4	5
Intent5	I intend to study abroad	1	2	3	4	5
Intent6	My family forced me to study abroad	1	2	3	4	5

(“R” denotes reverse-scored items)

Data collection

The design used for the study is a cross-sectional survey design that aims to measure the independent variables that are personality traits considered as factors affecting students' intention to study abroad. The study was conducted at high schools in Hanoi city in June 2019. In Vietnam, 12th graders have passed the high school graduation exam and have started enrolling in university. Data collection through a questionnaire survey of 400 students (n=350). Collected data were analyzed using SPSS 2.0 and SPSS AMOS 2.0 software. Fifty faulty questionnaires were discarded. There are two items removed because of Cronbach's Alpha < 0.5: Extraversion8 and Conscientiousness5. Only data collected from 300 questionnaires were included in the analysis. Demographic information, including gender and previous living abroad, is depicted in chart 2.

Chart 2. Frequency analysis

Factors	items	Male	Female	Total	Percentage
Previous international living	No previous international living	118	129	247	82.3
	Lived abroad	22	31	53	17.7
Parents annual income	50.000 USD-59.000 USD	14	11	25	8.3
	60.000 USD - 69.000 USD	61	75	136	45.3
	>69.000 USD	56	74	130	43.3

RESULTS**Reliability Analys**

Cronbach's Alpha coefficient is a coefficient that allows assessing if it is appropriate to include certain observed variables that belong to a research variable (latent variables, factors). Items in table 3 with Cronbach's Alpha coefficient greater than 0.7 should be accepted (Hair, 2006; Nunnally & Bernstein, 1994; Cortina, 1993).

Chart 3. Reliability analys

Item	Cronbach's alpha	Average Variance Extracted	Composite Reliability
Openness	0.964	0.731	0.964
Conscientiousness	0.862	0.454	0.863
Agreeableness	0.927	0.589	0.928
Neuroticism	0.879	0.478	0.880
Extraversion	0.843	0.425	0.837
Intent	0.747	0.749	0.947

Composite reliability is reasonable for a structure defined with five to eight items to meet the minimum threshold of 0.80 (Raykov, 1997; Brunner & Süß, 2005). Items in table 3 have aggregate confidence greater than 0.8. Thus, the items in chart 3 are satisfactory to perform the analysis of the next steps. The average Variance Extracted acceptance threshold of entries is greater than 0.50 (Hair, Black, Babin, & Anderson, 2010). Chart 3 shows that the items (openness, agreeableness, intent) have an Average Variance Extracted greater than 0.50, so these items are accepted for analysis to proceed with the next steps. Entries including (conscientiousness, neuroticism, extraversion) have Average Variance Extracted approximately = 0.5 but are still acceptable because if the Average Variance Extracted < 0.5, but the composite reliability is higher than 0.6, the convergent validity of the construct is still adequate (Fornell & Larcker, 1981). Chart 4 shows Extraction Sums of Squared

Loadings = 63,172%, Initial Eigenvalues of 6 factors = 2,234 (>1). As such, all of these indicators are valid for further analysis (Hair, Black, Babin, & Anderson, 2010).

Chart 4. Total Variance Explained

Component	Initial Eigenvalues			Extraction Sums of Squared Loadings			Rotation Sums of Squared Loadings		
	Total	% of Variance	Cumulative %	Total	% of Variance	Cumulative %	Total	% of Variance	Cumulative %
1	15.901	33.126	33.126	15.901	33.126	33.126	7.463	15.547	15.547
2	3.980	8.291	41.417	3.980	8.291	41.417	5.769	12.018	27.566
3	3.113	6.485	47.902	3.113	6.485	47.902	4.556	9.492	37.057
4	2.583	5.382	53.284	2.583	5.382	53.284	4.480	9.334	46.391
5	2.512	5.234	58.518	2.512	5.234	58.518	4.293	8.943	55.334
6	2.234	4.654	63.172	2.234	4.654	63.172	3.762	7.837	63.172

Extraction Method: Principal Component Analysis.

Factor Analysis

The condition for exploratory factor analysis is to satisfy the following requirements: Factor loading > 0.5. $0.5 \leq KMO \leq 1$: KMO coefficient (Kaiser-Meyer-Olkin) is an index used to consider the suitability of factor analysis (Cerny & Kaiser, 1977; Kaiser, 1974). Chart 5 shows that the Bartlett test has statistical significance (Sig.=0.00), coefficient KMO=0.948. The significant KMO coefficient means that factor analysis is appropriate. Bartlett test has statistical significance (Sig. < 0.05): This is a statistical quantity used to consider the hypothesis that variables do not correlate in the population. If this test is statistically significant (Sig. < 0.05), the observed variables are correlated in the population. Thus, the variables are valid for factor analysis (Snedecor, George, Cochran, & William, 1989).

Chart 5. KMO and Bartlett's Test

Kaiser-Meyer-Olkin Measure of Sampling Adequacy.		.948
Bartlett's Test of Sphericity	Approx. Chi-Square	9589.482
	df	1128
	Sig.	.000

Chart 6. Total Variance Explained

Component	Initial Eigenvalues			Extraction Sums of Squared Loadings			Rotation Sums of Squared Loadings		
	Total	% of Variance	Cumulative %	Total	% of Variance	Cumulative %	Total	% of Variance	Cumulative %
1	15.901	33.126	33.126	15.901	33.126	33.126	7.463	15.547	15.547
2	3.980	8.291	41.417	3.980	8.291	41.417	5.769	12.018	27.566
3	3.113	6.485	47.902	3.113	6.485	47.902	4.556	9.492	37.057
4	2.583	5.382	53.284	2.583	5.382	53.284	4.480	9.334	46.391
5	2.512	5.234	58.518	2.512	5.234	58.518	4.293	8.943	55.334
6	2.234	4.654	63.172	2.234	4.654	63.172	3.762	7.837	63.172

Extraction Method: Principal Component Analysis.

Factor loading (factor loading factor or factor weight) is the criterion to ensure the practical significance of factor analysis: Factor loading > 0.3 is considered to be the minimum level; Factor loading > 0.4 is considered necessary; Factor loading > 0.5 is considered to be of practical significance. Chart 6 shows that the factor loading of all variables is more significant than 0.6, which means that the factor analysis is valid (Hair, Anderson, Tatham, & Black, 1998).

Chart 7. Rotated Component Matrix

	Component					
	1	2	3	4	5	6
Openess9	.838					
Openess3	.831					
Openess7	.822					
Openess1	.816					
Openess5	.812					
Openess10	.808					
Openess2	.803					
Openess6	.803					
Openess4	.799					
Openess8	.798					
Agreeableness5		.762				
Agreeableness6		.761				
Agreeableness7		.758				
Agreeableness4		.747				
Agreeableness9		.747				
Agreeableness1		.740				
Agreeableness2		.729				

Agreeableness3		.700				
Agreeableness8		.685				
Neuroticism6			.739			
Neuroticism1			.736			
Neuroticism3			.712			
Neuroticism8			.710			
Neuroticism4			.685			
Neuroticism7			.654			
Neuroticism2			.636			
Neuroticism5			.619			
Intent4				.817		
Intent5				.815		
Intent3				.808		
Intent2				.794		
Intent1				.793		
Intent6				.773		
Conscientiousness6					.695	
Conscientiousness4					.693	
Conscientiousness2					.691	
Conscientiousness8					.687	
Conscientiousness9					.663	
Conscientiousness1					.638	
Conscientiousness3					.632	
Conscientiousness7					.627	
Extraversion6						.706
Extraversion3						.690
Extraversion7						.681
Extraversion4						.665
Extraversion1						.658
Extraversion8						.607
Extraversion2						.603
Extraction Method: Principal Component Analysis.						
Rotation Method: Varimax with Kaiser Normalization.						
a. Rotation converged in 6 iterations.						

Structural Equation Modeling (SEM)

The SEM model is an extension of the general linear model (GLM) that allows the researcher to test a set of regression equations simultaneously. The SEM model combines all the techniques such as multivariate regression, factor analysis and correlation analysis (between elements in the network diagram) to check the complex relationship fit in the model. Unlike other statistical techniques that only allow estimation of the partial relationship of each pair of factors (elements) in the classical model (measurement model). SEM allows the simultaneous estimation of the elements in the model. the overall model estimates the causal relationship between the latent concepts (Latent Constructs) through indicators that combine both measurement and structure of the theoretical model, measure the stable relationships (recursive) and non-recursive, measuring direct and indirect effects, including measurement error

and residual correlation. With the confirmatory factor analysis (CFA) technique, the SEM model allows the flexibility to find the most suitable model among the proposed models (Crowley & Fan 1997; Kline, 2011; Nachtigall, Kroehne, Funke, & Steyer), 2003; Raykov & Marcoulides, 2006; Ullman, 2006; Widaman & Thompson, 2003).

To evaluate the fit of the SEM model, the Chi-Square (χ^2) testing, Root-Mean-Square Error of Approximation (RMSEA) procedure (Browne & Cudeck, 1993) together with the confidence interval, standardized-root-mean square, is required. Residual (SRMR), Tucker-Lewis Index (TLI) (Tucker & Lewis, 1973), and Comparative Fit Index (CFI) (Bentler, 1990) were reported. It is suggested that a good fitting model should have values of CFI and TLI $\geq .90$, RMSEA and SRMR $\leq .08$ (Browne & Cudeck, 1993; Byrne, 1989; Hu & Bentler 1999; Kline, 2011).

The results of SEM analysis show that openness personality has a positive and significant relationship with intention to study abroad with Regression Weights coefficient = 0.131 and reliability p-value = 0.056 (approximately 0.050 still has some acceptable). Hypothesis H1. Extraversion personality positive and significant impact on intention to study abroad can be accepted.

Agreeableness has a positive and significant relationship with intention to study in a university with Regression Weights = 0.191 and reliability p-value = 0.012. Hypothesis H2. Personality Neuroticism has a positive and significant impact on the intention to study abroad in an accepted university.

Personality neuroticism has a positive and significant relationship with intention to study abroad with Regression Weights = 0.299 and reliability p-value = 0.000. Hypothesis H3. Agreeableness has a positive and significant effect on the intention to study abroad.

Extraversion personality has a positive and significant relationship with intention to study abroad with Regression Weights = 0.265 and reliability p-value = 0.002. Hypothesis H4. Conscientiousness personality has a positive and significant impact on the intention to study abroad to be accepted.

Conscientiousness has a positive and significant relationship with intention to study abroad with Regression Weights = 0.265 and reliability p-value = 0.046 hypothesis H5. Openness personality has a positive and significant effect on the intention to study abroad in an accepted university.

Chart 8. Regression Weights

			Estimate	S.E.	C.R.	P	
intent	<---	openess	.131	.068	1.913	.056	accept
intent	<---	agreeableness	.191	.076	2.510	.012	accept
intent	<---	neuroticism	.299	.081	3.697	***	accept
intent	<---	extraversion	.265	.087	3.053	.002	accept
intent	<---	conscientiousness	.179	.090	1.991	.046	accept

Chart 1. SEM analysis results

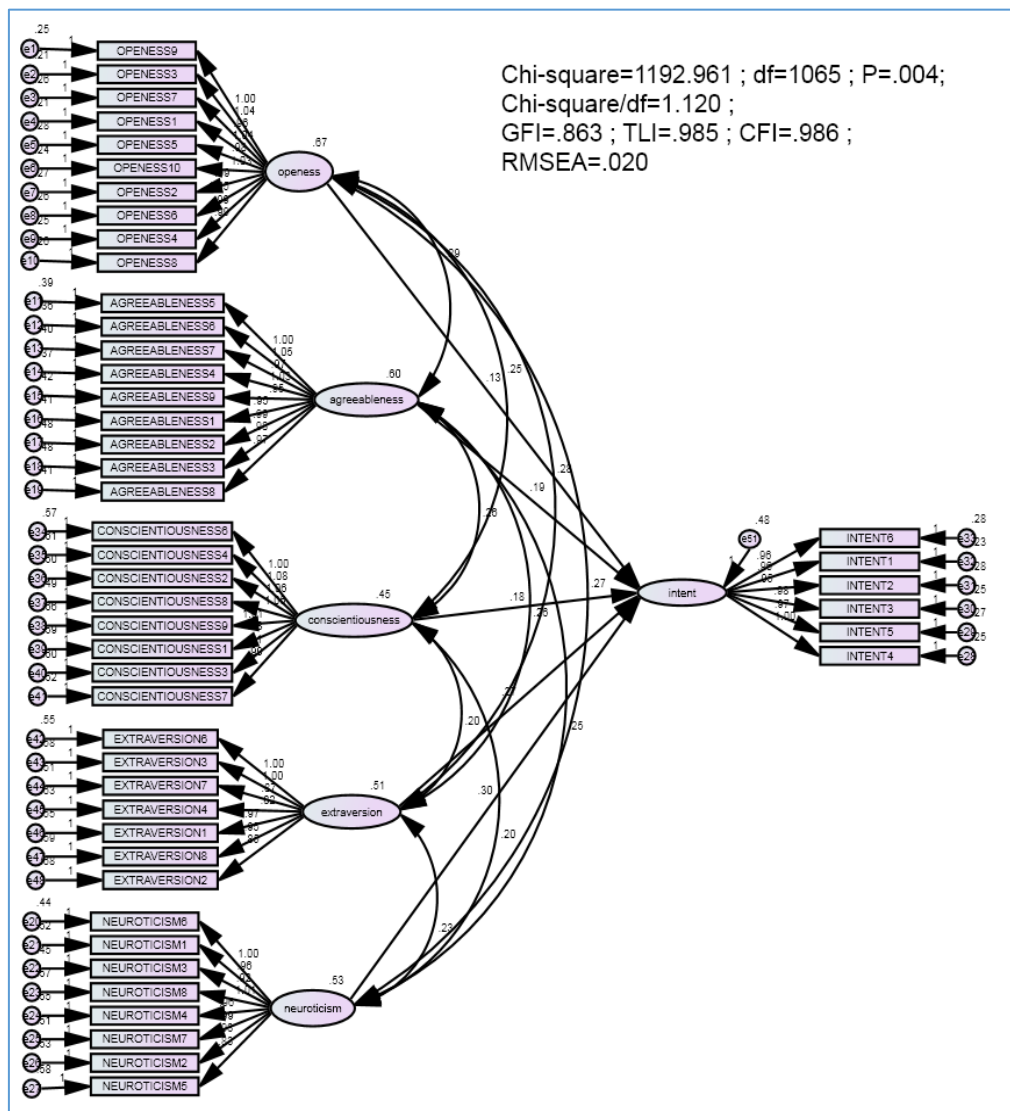

About model fit, the analysis results (Chart 1) show that Chi-square=11.92961; Df=1065; P-value=0.04; Chi-square/df=1.120; GFI=0.863; TLI=0.985; CFI=0.986; RMSEA=0.020. Thus, all coefficients meet the requirements. Particularly for a GFI of approximately 0.9 is acceptable (Browne & Cudeck, 1993; Tucker & Lewis, 1973; Bentler, 1990; Browne & Cudeck, 1993; Byrne, 1989; Hu & Bentler 1999; Kline, 2011).

DISCUSSION

Key Findings

First, this study finds that Extraversion personality has a positive and significant association with high intention to study abroad. Thus, hypothesis H1. Extraversion personality has a positive and significant effect on the intention to go to university to be accepted. The impact of extraversion personality on intention to study abroad is high compared to other methods (Regression Weights = 0.265). Extraversion people have a high impact on

their intention to study abroad because they are: warm people - make friends easily, sociable - like large gatherings, assertive - take responsibility, cheerful - always busy; looking for excitement - likes a buzzing atmosphere; have a lot of positive emotions - radiate joy; creative, always ready to learn new things and focused on overcoming challenges (John, Naumann & Soto, 2008; McCrae & Costa, 2008); Barrick, Mount, 1991). It is similar to a study by (Frieze et al., 2004; Misra, Ghosh, & Kanungo, 1990) that people with an immigrant, open-minded personality put career at the center of a priority. Language-conscious migration is also part of the culture, and, naturally, international students will choose to study in a country where they can communicate in the host country's language, as that prerequisites for their studies and social life in their home country (Bourke, 2000; McCarthy, Sen & Fox Garrity, 2012). It is similar to the study of Clavel (2015); Eder & Smith, & Pitts (2010) that immigrant personalities choose to study in a country with an "interesting" culture and utterly different from their own to gain valuable life experience. Similarly, Hemsley-Brown (2012), Hemsley-Brown & Oplatka (2015), Mazzarol & Soutar (2002) and Price et al. (2003) explore personality migration concerning the desire to experience fame of countries and universities have a significant impact on attracting international students to apply for admission.

Second, this study explores that personality Neuroticism has the highest positive and significant association with intention to study abroad (Regression Weights = 0.299). It means hypothesis H2. Personality Neuroticism has a positive and significant pact on the intention to study abroad in an accepted university. People with Neuroticism personalities have high scores on anxiety, anger easily; often depressed; vulnerable to intimidation; hurry; vulnerable, so they are greatly affected by social pressure to study abroad (Tuan, 2017). Exploring the factors affecting Vietnamese students' intention to study abroad, (Tu & Hang, 2016) discovered that social pressure is a factor that positively and significantly affects the decision to study abroad.

Third, this study shows that Agreeableness personality has a positive and significant association with intention to study abroad. However, the impact was moderate (Regression Weights = 0.191). Thus, hypothesis H3. Agreeableness has a positive and significant effect on the intention to study abroad. Others significantly influence people, easily conform to the will of others, and empathize with others, so their intention to study may have a significant influence from family, friends, and those around them around. In Vietnam, the career orientation of parents towards their children in the family is an essential and meaningful thing in the future career development of their children (Dang, 2010). In Vietnam, the family plays a significant role in forming professional qualities for children (Nguyen & Le, 2018). Some admitted that they did not want to study abroad, but their family asked them to seek immigration opportunities (Tran, 2019). Studies in other countries have also shown that having a family relationship can profoundly affect life (Umberson & Montez, 2010). Family connections can provide greater meaning and purpose and social and tangible resources conducive to well-being (Hartwell & Benson, 2007; Kawachi & Berkman, 2001). Much research

on the parent-child relationship has a significant impact on children's transition during adulthood (Aquilino, 2006; McHale & Crouter, 1996).

Fourth, this study shows that Conscientiousness personality has a positive and significant relationship with intention to study abroad. That is, hypothesis H4. Conscientiousness personality has a positive and significant effect on studying abroad, but the impact is not significant (Regression Weights = 0.179). A person with a conscientious disposition is thoughtful, has control over anger, and has clear goals. Capable of completing work successfully; comply with the rules; thirst for achievement, hard work; cautious, so they are very cautious when intending to study abroad at university. It is probably the reason that the coefficient of Regression Weights is low.

Fifth, this study shows that Openness personality has a positive and significant association with intention to study abroad. Thus, hypothesis H5. Openness personality has a positive and significant impact on the intention to study abroad, but the regression weights are not high (Regression Weights = 0.131). Although open people have intense emotional experiences, prefer variety over repetition, prefer complex problems. People who score high in this trait tend to be exploratory and creative. They are genuinely creative, always ready to learn new things and focused on overcoming challenges (John, Naumann & Soto, 2008; McCrae & Costa, 2008); Barrick & Mount, 1991). However, it is surprising that the impact of this personality on intention to study abroad is shallow. In contrast to studies that have discovered that openness-minded individuals enjoy an enjoyable cultural experience as one of the most critical factors in international students choosing a study abroad destination (Eder, Smith, & Pitts, 2010).). Open-minded people focus on imagination and insight. People with these characteristics are often inquisitive about everything around them. They are genuinely creative, always ready to learn new things and focused on overcoming challenges (John, Naumann & Soto, 2008; McCrae & Costa, 2008); Barrick & Mount, 1991). Therefore, more research is needed to uncover this exciting secret.

Among the five personality traits that have a positive and significant impact on the intention to study abroad, neuroticism has the most significant regression coefficient (Regression Weights = 0.299), the second is extraversion (Regression) Weights = 0.265), and the second is personality agreeableness (Regression Weights = 0.191). The remaining personality traits insignificantly affect the intention to study abroad (compassionate personality with Regression Weights = 0.179, openness personality with Regression Weights = 0.131). This study is similar to McCarthy et al. (2012) that personality traits are associated with attitudes towards study abroad immigrants. The five personality traits make for a compelling explanation of social attitudes and behaviour because it is internal to the individual and, to a large extent, pre-empts adult social experiences: it is systematic—large genetic numbers (Medland & HHri, 2009; Yamagata et al., 2006).

Implications

Foreign universities and businesses providing study abroad consulting services when marketing higher education should pay attention and learn about the personality of Vietnamese students because there are differences in personality about students. Their intention to study abroad. Attention should be paid to neuroticism and extraversion because these two traits affect studying abroad with high Regression Weights. The State of Vietnam, local authorities in Vietnam, when implementing the policy of financing the training of Vietnamese young people abroad, among other factors, should pay attention to understanding the characteristics of young people to avoid wasting away public investment fees.

Limitations

As with other empirical studies, there are limitations to this study that should be considered when discussing the results. First, the paper-and-pencil survey method was used in this study, which reflects the respondents' subjective perception of the investigated questions. Therefore, the data is still subjective of the respondents to the questionnaire (Pakpour, Gellert, Asefzadeh, Updegraff, Molloy & Sniehotta, 2016). Furthermore, our data is collected over a single period. The non-probability sampling method is limited in generalizing and inferring about the entire population.

Second, this study focuses on exploring the relationship between personality and intention to study abroad. Some other factors have been ignored, such as the difference in demographic factors such as gender, parents' income. It is also possible to evaluate the influencing factors for the intention to study abroad at university. We are studied by the theory of planned behaviour, the theory of reasoned action (Ajzen, 1987). Future studies should also assess the impact of additional factors that were not included in our analysis. Our research was done in a Vietnamese cultural context. Studying in other cultural contexts and drawing generalized conclusions by research develops a different research paradigm (Sun, Fang, Lim & Straub, 2012).

CONCLUSIONS

In recent years, the number of Vietnamese students studying abroad has increased. However, several new studies have found push and pull factors about the decision to study abroad. This study is a quantitative study examining the relationship between 5 personality traits and the intention of Vietnamese students to study abroad. Research results show that all five personality traits have a positive and significant impact on the intention of Vietnamese students to study abroad. These findings have contributed to enriching the research literature on personality traits and intention to study abroad. The conclusions of this study provide useful information for educational policymakers, universities, businesses and organizations providing study abroad consulting services. It should be recalled that the sample size in this study was small; therefore, it would be beneficial to repeat this study using a larger sample group from a more diverse population. The limitations of the convenient sampling method have

certain limitations, so it is necessary to use the random probability sampling method to limit errors in the prediction.

REFERENCES

- Ajzen I (1991) The theory of planned behavior. *Organ Behav Hum Decis Process* 50(2):179–211.
- Ajzen I, Madden TJ (1986) Prediction of goal-directed behavior: attitudes, intentions, and perceived behavioral control. *J Exp Soc Psychol* 22(5):453–474.
- Ajzen, I. (2006). *Constructing a TpB Questionnaire: Conceptual and Methodological Considerations*. <http://www.people.umass.edu/aizen/pdf/tpb.measurement.pdf>.
- Akrami, N., B. Ekehammar, and R. Bergh. (2011). Generalized Prejudice: Common and Specific Components. *Psychological Science* 22 (1): 57–59. doi:10.1177/0956797610390384.
- Allik, J., and R. R. McCrae. (2004). Toward a Geography of Personality Traits: Patterns of Profiles across 36 Cultures. *Journal of Cross-Cultural Psychology* 35 (1): 13–28. doi:10.1177/0022022103260382.
- Ashwill, M. (2018). *Viet Nam Ranks 5th in International Enrollment in 3 Countries*. <https://markashwill.com/2018/05/16/viet-nam-ranks-5th-international-enrollment-in-3-countries/>
- Barrick, M. R., and Mount, M. K. (1991). The Big Five Personality Dimensions and Job Performance: A Meta-Analysis. *Personnel Psychology*, 44(1), S. 1–26.
- Bentler, P. M. (1990). Comparative fit indexes in structural models. *Psychological Bulletin*, 107, 238–246. <https://doi.org/10.1037/0033-295X.86.5.452>
- Bloom, L. (2000). Intentionality and theories of intentionality in development. *Hum Dev*, 43(3), 178–185.
- Bodewig, C., Badiani-Magnusson, R., & Macdonald, K. (2014). *Skilling up Vietnam: Preparing the workforce for a modern market economy*. Washington DC: World Bank Publications.
- Bodycott, P. (2009). Choosing a Higher Education Study Abroad Destination – What Mainland Chinese Parents and Students Rates as Important. *Journal of Research in International Education*, 8(3), 349-373
- Bourke, A. (2000). A Model of the Determinants Of international Trade in Higher Education. *The Service Industries Journal*, 20, 110-318. <http://dx.doi.org/10.1080/026420600000000007>
- Browne, M. W., & Cudeck, R. (1993). *Alternative ways of assessing model fit*. In K. A. Bollen & J. S. Long (Eds.). *Testing structural equation models* (pp. 136–162). Newbury Park, CA: Sage.
- Brunner, M. & Süß, H. (2005). *Analyzing the Reliability of Multidimensional Measures: An Example from Intelligence Research*. <http://citeseerx.ist.psu.edu/viewdoc/download?doi=10.1.1.856.4612&rep=rep1&type=pdf>
- Byrne, B. M. (1989). *A primer of LISREL: Basic applications and programming for confirmatory factor analytic models*. New York: Springer. <https://doi.org/10.1007/978-1-4613-8885-2>
- Canli, T. (2008). *Toward a “Molecular Psychology” of Personality*. In *Handbook of Personality: Theory and Research*, 3rd ed., edited by O.

- P. John, R. W. Robins, and L. A. Pervin, 311–327. New York: Guilford.
- Carney, Dana R., John T. Jost, Samuel D. Gosling, and Jeff Potter. (2008). The Secret Lives of Liberals and Conservatives: Personality Profiles, Interaction Styles, and the Things They Leave Behind. *Political Psychology*, 29 (6): 807–840. doi:10.1111/j.1467-9221.2008.00668.x.
- Caspi, A., and B. W. Roberts. (2001). Personality Development across the Life Course: The Argument for Change and Continuity. *Psychological Inquiry*, 12 (2): 49–66. doi:10.1207/S15327965PLI1202_01.
- McCrae, R. R., & Costa Jr., P. T. (2008). *The Five-Factor Theory of Personality*. In O. P. John, R. W. Robins, & L. A. Pervin (Eds.), *Handbook of Personality: Theory and Research* (3rd ed., pp. 159-181). New York: Guilford Press.
- Cerny, C.A., & Kaiser, H.F. (1977). A study of a measure of sampling adequacy for factor-analytic correlation matrices. *Multivariate Behavioral Research*, 12(1), 43-47.
- Chen, C.H., and Zimitat, C. (2006). Understanding Taiwanese Students' Decision-Making Factors Regarding Australian International Higher Education. *International Journal of Educational Management*, 20(2), 91-100
- Cheung, A.C.K, Yuen, T.W.W., Yuen, C.Y.M., and Cheng, Y.C. (2011). Strategies and Policies for Hong Kong's Higher Education in Asian Markets: Lessons from the United Kingdom, Australia, and Singapore. *International Journal of Educational Management*, 25(2), 144-163.
- Chung, K.C., Holdsworth, D.K., Li, Y.Q., and Fam, K.S. (2009). Chinese 'Little Emperor', Cultural Values and Preferred Communication Sources for University Choice. *Young Consumers: Insight and Ideas for Responsible Marketers*, 10(2), 120-132.
- Claes Fornell and David F. Larcker.(1981). Evaluating Structural Equation Models with Unobservable Variables and Measurement Error. *Journal of Marketing Research*. Vol. 18, No. 1 (Feb., 1981), pp. 39-50
- Clark, N . (2013). Vietnam: Trends in international and domestic education. *World Education News & Review*, 1 June, viewed 17 March 2015. <http://wenr.wes.org/2013/06/vietnam-trends-in-international-and-domestic-education/>.
- Clavel, T .(2015). Culture, cost and proximity draw Chinese students to Japan. *The Japan Times*, 22 April, viewed 1 July 2015. <http://www.japantimes.co.jp/community/2015/04/22/issues/culture-cost-proximity-draw-chinese-students-japan/#.VZPZsUYnIXx>.
- Cortina, J. M. (1993). What is coefficient alpha? An examination of theory and applications. *Journal of applied psychology*, 78(1), 98.
- Counsell, D. (2011). Chinese Students Abroad: Why They Choose the UK And How They See Their Future. *China: an international journal*, 9(1), 48-71
- Crowley, S. L., & Fan, X. (1997). Structural equation modeling: Basic concepts and applications in personality assessment research. *Journal of Personality Assessment*, 68(3), 508–531. https://doi.org/10.1207/s15327752jpa6803_4

- Cubillo, J.M., Sánchez, J., and Cerviño, J. (2006). International Students' Decision-Making Process. *International Journal of Educational Management*, 20(2), 101-115. 49
- Dang Thanh Nhan. (2010). Career orientation for children. *Family and Gender Studies Journal*, N.5 (2010), 27-38
- Denissen, J. J. A., and L. Penke. (2008). Motivational Individual Reaction Norms Underlying the Five-factor Model of Personality: First Steps towards a Theory-Based Conceptual Framework. *Journal of Research in Personality*, 42 (5): 1285–1302. doi:10.1016/j.jrp.2008.04.002.
- Doherty, B., & Evershed, N. (2018, 24 March 2018). The changing shape of Australia's immigration policy. *The Guardian*. <https://www.theguardian.com/australia-news/2018/mar/24/australias-fierce-immigration-debate-is-about-to-get-louder>.doi:0.32674/jis.v0i0.731ojed.org/jis
- Eder, J, Smith, WW & Pitts, RE. (2010). Exploring factors influencing student study abroad destination choice. *Journal of Teaching in Travel & Tourism*, vol. 10, no. 3, pp. 232-50.
- Ekehammar, B., and N. Akrami. (2003). The Relation between Personality and Prejudice: A Variable and a Person Centred Approach. *European Journal of Personality*,17 (6): 449–464. doi:10. 1002/per.494.
- Engelke, M. (2008). *Internationalisation of the Swedish Higher Education System: An Impact Analysis on Student and Employee Satisfaction*. (Master dissertation). Blekinge Institute of Technology, Sweden.
- English, A. S., Allison, J., & Ma, J. H. (2016). Understanding Western students: Motivations and benefits for studying in China. *Journal of Education and Training Studies*, 4(8), 44-55.
- Frieze, I. H., Boneva, B. S., Sarlija, N., Horvat, J., Ferligoj, A., Kogovsek, T., . . . Jarosova, E. (2004). Psychological differences in stayers and leavers: Emigration desires in Central and Eastern European university students. *European Psychologist*, 9(1), 15-23. doi: 10.1027/1016-9040.9.1.15
- Gerber, A. S., G. A. Huber, D. Doherty, and C. M. Dowling. (2011). The Big Five Personality Traits in the Political Arena. *Annual Review of Political Science* 14 (1): 265–287. doi:10.1146/annurev-polisci-051010-111659.
- Gerber, A. S., G. A. Huber, D. Doherty, C. M. Dowling, and S. E. Ha. (2010). Personality and Political Attitudes: Relationships across Issue Domains and Political Contexts. *American Political Science Review*, 104 (1): 111–133. doi:10.1017/S0003055410000031.
- Gerber, A. S., G. A. Huber, D. Doherty, C. M. Dowling, C. Raso, and S. E. Ha. (2011b). Personality Traits and Participation in Political Processes. *The Journal of Politics*, 73 (3): 692–706. doi:10.1017/S0022381611000399.
- Goldberg, L. R. (1993). The structure of phenotypic personality traits. *American Psychologist*, 48(1), 26–34. <https://doi.org/10.1037/0003-066X.48.1.26>
- Hair, J., Anderson, R., Tatham, R. and Black, W. (1998) *Multivariate data analysis*. 5th Edition, Prentice Hall, New Jersey.

- Hair, J., Black, W., Babin, B., and Anderson, R. (2010). *Multivariate data analysis* (7th ed.): Prentice-Hall, Inc. Upper Saddle River, NJ, USA.
- Hair Jr., J. F., Black, W. C., Babin, B. J., Anderson, R. E., & Tatham, R. (2006). *Multivariate Data Analysis*. New Jersey: Pearson International Edition
- Hampson, S. E., and L. R. Goldberg. (2006). A First Large Cohort Study of Personality Trait Stability over the 40 Years between Elementary School and Midlife. *Journal of Personality and Social Psychology*, 91 (4): 763–779. doi:10.1037/0022-3514.91.4.763.
- Harman, G, Hayden, M & Nghi, PT (2010). *Higher education in Vietnam: reform, challenges and priorities*. Springer, The Netherlands.
- Heine, S. J., and E. E. Buchtel.(2009). Personality: The Universal and the Culturally Specific. *Annual Review of Psychology* 60 (1): 369–394. doi:10.1146/annurev.psych.60.110707.163655.
- Hemsley-Brown, J & Oplatka, I. (2015). University choice: what do we know, what don't we know and what do we still need to find out?. *International Journal of Educational Management*, vol. 29, no. 3, pp. 254-74.
- Hemsley-Brown, J. (2012). The best education in the world: reality, repetition or cliché? International students' reasons for choosing an English university. *Studies in Higher Education*, vol. 37, no. 8, pp. 1005-22.
- Ho Quoc Tuan. (2017). *Story "fad" to study abroad*. [Translated from original Vietnamese].<https://www.thesaigontimes.vn/264943/chuyen-mot-du-hoc.html>
- Hu, L. T., & Bentler, P. M. (1999). Cutoff criteria for fit indexes in covariance structure analysis: Conventional criteria versus new alternatives. *Structural Equation Modeling. A Multidisciplinary Journal*, 6(1), 1-55. <https://doi.org/10.1080/10705519909540118>
- Jin, L., Watkins, D., & Yuen, M. (2009). Personality, career decision self-efficacy and commitment to the career choices among Chinese graduate students. *Journal of Vocational Behavior*, 74(1), 47-52.
- John, O. P., L. P. Naumann, and C. J. Soto. (2008). *Paradigm Shift to the Integrative Big Five Trait Taxonomy: History, Measurement, and Conceptual Issues*. In *Handbook of Personality: Theory and Research*, edited by O. P. John, R. W. Robins, and L. A. Pervin, 114–158. New York: Guilford.
- Jost, J. T. (2006). The End of the End of Ideology. *American Psychologist*, 61 (7): 651–670. doi:10.1037/0003-066X.61.7.651.
- Jost, J. T., B. A. Nosek, and S. D. Gosling. (2008). Ideology: Its Resurgence in Social, Personality, and Political Psychology. *Perspectives on Psychological Science* 3 (2): 126–136. doi:10.1111/j.1745-6916.2008.00070.x..
- Kaiser, H. (1974). An index of factor simplicity. *Psychometrika*, 39: 31–36.
- Kline, R.B. (2011). *Principles and Practice of Structural Equation Modeling*. New York: Guilford Press.
- Kritz, M. M. (2012). Globalization of higher education and international student mobility. *Comparative Education Review*, 57(4), 609-636.
- Landes, D. (2008). Paper Study College Fee for Non-Europeans. The Local - Sweden's News in English. <http://www.thelocal.se/12702/20080627/>

- Lee, Christina Kwai Choi & Morrish, Sussie C.(2012). Cultural values and higher education choices: Chinese families. *Australasian marketing journal*, Elsevier, vol. 20(1), pages 59-64. DOI: 10.1016/j.ausmj.2011.10.015
- Leung, SE. (2010). Vietnam: an economic survey. *Asian-Pacific Economic Literature*, vol. 24, no. 2, pp. 83-103.
- Liu, D., & Morgan, W. J. (2016). Students's decision-making about postgraduate education at G University in China: The main factors and the role of family and of teachers. *The Asia-Pacific Education Researcher*, 25(2), 325-335.
- Nghia, Tran. (2017). Developing generic skills for students via extra-curricular activities in Vietnamese universities: Practices and influential factors. *Journal of Teaching and Learning for Graduate Employability*, 8. 22. 10.21153/jtlge2017vol8no1art624.
- Maringe, F. (2006). University and Course Choice: Implications for Positioning, Recruitment and Marketing. *International Journal of Educational Management*, 20(6), 466-479
- Maringe, F., and Carter, S. (2007). International Students's Motivations for Studying in UK HE: Insights Into The Choice and Decision Making Of African Students. *International Journal of Educational Management*, 21(6), 459-475
- Marusic, I., Kamenov, Z., & Jelic, M. (2011). Personality and attachment to friends. *Drustvena Istrazivanja*, 20(4), 1119–1137. doi: 10.1002/per.515
- Mazzarol, T & Soutar, GN. (2002). Push-pull factors influencing international student destination choice. *International Journal of Educational Management*, vol. 16, no. 2, pp. 82-90.
- Mazzarol, T., and Soutar, G.N. (2000). Push-Pull Factors Influencing International Student Destination Choice. *International Journal of Educational Management*, 16(2), 82-90
- McCarthy, Erin E. and Sen, Arup K. and Fox Garrity, Bonnie. (2012). Factors that Influence Canadian Students' Choice of Higher Education Institutions in the United States (2012). *Business Education & Accreditation*, v. 4 (2) pp. 85-95, 2012. Available at SSRN: <https://ssrn.com/abstract=2144995>.
- McEachan, C., Conner, M., Taylor, N., & Lawton, R. (2011). Prospective prediction of health-related behavior with the TPB: a meta-analysis. *Health Psychology Review*, 5(2), 97 – 144.
- Medland, S. E., and P. K. Hatemi. (2009). Political Science, Biometric Theory, and Twin Studies: A Methodological Introduction. *Political Analysis*, 17 (2): 191–214. doi:10.1093/pan/mpn016.
- Mischel, W., and Y. Shoda .(1995). A Cognitive-affective System Theory of Personality: Reconceptualizing Situations, Dispositions, Dynamics, and Invariance in Personality Structure. *Psychological Review*, 102 (2): 246–268. doi:10.1037/0033-295X.102.2.246.
- Misra, S., Ghosh, R., & Kanungo, R. N. (1990). Measurement of family involvement: A cross-national study of managers. *Journal of Cross-Cultural Psychology*, 21(2), 232-248.
- Mondak, J. J. (2010). *Personality and the Foundations of Political Behavior*. New York: Cambridge University Press.

- Mondak, J. J., and K. D. Halperin.(2008). A Framework for the Study of Personality and Political Behaviour. *British Journal of Political Science*, 38 (2): 335–362. doi:10.1017/S000712340 8000173.
- Mondak, J. J., M. V. Hibbing, D. Canache, M. A. Seligson, and M. R. Anderson.(2010). Personality and Civic Engagement: An Integrative Framework for the Study of Trait Effects on Political Behavior. *American Political Science Review*, 104 (1): 85–110. doi:10.1017/S0003055 409990359.
- Nachtigall, C., Kroehne, U., Funke, F., & Steyer, R. (2003). (Why) should we use SEM? Pros and cons of structural equation modeling. *Methods of Psychological Research Online*, 8(2),1-22.
- Nchise, Abinwi. (2012). An Empirical Analysis of the Theory of Planned Behavior, A Review of Its Application on E-democracy Adoption Using the Partial Least Squares Algorithm. *JeDEM*. 4. 171-182. 10.29379/jedem.v4i2.129.
- Nghia, Tran. (2015). *Factors influencing prospective international students's motivation for overseas study and selection of host countries and institutions: The case of Vietnamese students*. Paper presented at the 26th ISANA International Education Association Conference, Melbourne, Australia, 1-4 December, 2015..
- Nguyen Hong Chi. (2013). Vietnamese international student mobility: past and current trends. *Asian Education & Development Studies*, vol. 2, no. 2, pp. 127-48.
- Nguyen Thai Quynh Trang. How much money do Vietnamese who study abroad contribute to other national economies?. <http://cafef.vn/du-hoc-sinh-viet-dong-gop-bao-nhieu-tien-cho-cac-nen-kinh-te-2018111919240805.chn>
- Nguyen Xuan Thanh, Le Thi Ha Giang. The role of families in career guidance for high school students. <https://doanhnhanplus.vn/vai-tro-cua-gia-dinh-trong-hoat-dong-huong-nghiep-cho-hoc-sinh-trung-hoc-pho-thong-361281.html>
- Nguyen, H. C. (2013). Vietnamese international student mobility: past and current trends. *Asian Education & Development Studies*, 2(2), 127-148.
- Nunnally, J.C. and Bernstein, I.H. (1994). The Assessment of Reliability. *Psychometric Theory*, 3, 248-292.
- Parafianowicz, L. (2009). Foreign Student Fees Delayed Until 2011. The Local - Sweden's News In English. <http://www.thelocal.se/19410/20090512/>
- Petruzzellis, L., and Romanazzi, S. (2010). Educational Value: How Students Choose University: Evidence From An Italian University. *International Journal of Educational Management*, 24(2), 139-158
- Phan Anh Tu, Trinh Thuy Hang. (2016). Research the factors affecting the intention of studying abroad after graduating of university of economics students in Can Tho University. *Can Tho University Journal of Science*. 46d: 122-129.
- Pimpa, N. (2003). The Influence of Family on Thai Students' Choices Of International Education. *International Journal of Educational Management*, 17(5), 211-219
- Price, I, Matzdorf, F, Smith, L & Agahi, H . (2003). The impact of facilities on student choice of university. *Facilities*, vol. 21, no. 10, pp. 212-22.

- Raykov, T. (1997). Estimation of composite reliability for congeneric measures. *Applied Psychological Measurement*, 21(2), 173-184.
- Raykov, T., & Marcoulides, G. (2006). *A first course in structural equation modeling* (2nd Ed.). Mahwah, NJ: Lawrence Erlbaum.
- Schmitt, D. P., J. Allik, R. R. McCrae, and V. Benet-Martinez. (2007). The Geographic Distribution of Big Five Personality Traits: Patterns and Profiles of Human Self-description across 56 Nations. *Journal of Cross-cultural Psychology*, 38 (2): 173–212. doi:10.1177/0022022106297299.
- Shultz, C.J. (2012). Vietnam: Political Economy, Marketing System. *Journal of Macromarketing*, vol. 32, no. 1, pp. 7-17.
- Sibley, C. G., and J. Duckitt. (2008). Personality and Prejudice: A Meta-analysis and Theoretical Review. *Personality and Social Psychology Review*, 12 (3): 248–279. doi:10.1177/1088868308319226.
- Sirat, M, Azman, N & Bakar, AA. (2014). Towards harmonization of higher education in Southeast Asia. *Inside Higher Ed*, 13 April, viewed 22 July 2015.
- Snedecor, George W. and Cochran, William G. (1989). *Statistical Methods* (Eighth Edition). Iowa State University Press.
- Spinks, H .(2016). *Overseas students: immigration policy changes 1997-2015*. Parliamentary Library research paper series 2015-16, 25 February 2016, Parliament of Australia, Canberra, viewed 01 Apr 2020.
http://www.aph.gov.au/About_Parliament/Parliamentary_Departments/Parliamentary_Library/pubs/rp/rp1516/OverseasStudents.
- Tariq J, Sajjad A, Usman A, Amjad A. (2017). The role of intentions in facebook usage among educated youth in Pakistan: an extension of the theory of planned behavior. *Comput Hum Behav*, 74:188–195.
- Terracciano, A., R. R. McCrae, and P. T. Costa.(2010). Intra-individual Change in Personality Stability and Age. *Journal of Research in Personality*, 44 (1): 31–37. doi:10.1016/j.jrp.2009.09.006.
- Tran Le Huu Nghia. (2019). Motivations for Studying Abroad and Immigration Intentions: The Case of Vietnamese Students. *Journal of International Students* Volume 9, Issue 3 (2019), pp. 758-776.ISSN: 2162-3104 (Print), 2166-3750 (Online) doi: 10.32674/jis.v0i0.731ojed.org/jis
- Tran, L. T., & Vu, T. T. P. (2016). I'm not like that, why treat me the same way? The impact of stereotyping international students on their learning, employability and connectedness with the workplace. *The Australian Educational Researcher*, 43(2), 203-220.
- Tucker, L. R., & Lewis, C. (1973). A reliability coefficient for maximum likelihood factor analysis. *Psychometrika*, 38, 1–10. <https://doi.org/10.1007/BF02291170>
- Ullman, J. B. (2006). Structural equation modeling: Reviewing the basics and moving forward. *Journal of Personality Assessment*, 87(1), 35-50.https://doi.org/10.1207/s15327752jpa8701_03
- Warshaw PR, Davis FD.(1984). Self-understanding and the accuracy of behavioral expectations. *Personal Soc Psychol Bull*, 10(1):111–118.

- Welch, A. (2013). Ho Chi Minh meets the market: Public and private higher education in Viet Nam. *International Education Journal: Comparative Perspectives*, vol. 8, no. 3, pp. 35-56.
- Widaman, F., & Reise, S. P. (1997). *Exploring the measurement invariance of psychological instruments: Applications in the substance use domain*. In K. J. Bryant, M. Windle, & S. G. West (Eds.), *The science of prevention: Methodological advances from alcohol and substance abuse research* (pp. 281-324). Washington, DC: American Psychological Association. <https://doi.org/10.1037/10222-009>
- World Bank 2015, Vietnam. <http://data.worldbank.org/country/vietnam>.
- World Bank 2008, Vietnam: Higher education and skills for growth, World Bank, viewed 08/04 2015. <https://openknowledge.worldbank.org/handle/10986/7814>.
- Yamagata, S., A. Suzuki, J. Ando, Y. Ono, N. Kijima, K. Yoshimura, F. Ostendorf, et al. (2006). Is the Genetic Structure of Human Personality Universal? A Cross-cultural Twin Study from North America, Europe, and Asia. *Journal of Personality and Social Psychology*, 90 (6): 987–998. doi:10.1037/0022-3514.90.6.987.