

## PalArch's Journal of Archaeology of Egypt / Egyptology

### CUSTOMER LOYALTY TO PREPAID CARD: THE SURVEY ON STUDENT AS IM3 USERS IN LAMPUNG, INDONESIA

*Ridho Bramulya Ikhsan*<sup>1\*</sup>, *Johannes Widjaja Wahono*<sup>2</sup>, *Rudy Kodirun*<sup>3</sup>  
Management Department, BINUS Online Learning, Bina Nusantara University,  
Indonesia.11480

[ridho.bramulya.i@binus.ac.id](mailto:ridho.bramulya.i@binus.ac.id)

**Ridho Bramulya Ikhsan, Johannes Widjaja Wahono, Rudy Kodirun: Customer Loyalty to Prepaid Card: The Survey on Student as IM3 Users in Lampung, Indonesia-- Palarch's Journal Of Archaeology Of Egypt/Egyptology 18(1), ISSN 1567-214x**

**Keywords: service quality, product quality, price, switching cost, customer satisfaction, customer loyalty**

#### **Abstract**

This study investigates the effects of service quality, product quality, price, and switching cost towards satisfaction and its impact on loyalty of IM3 card users. The research is done on IM3 prepaid card users in Lampung Province with a total sample of 160 users. The methods used are descriptive statistical analysis and structural equation model analysis. The calculation result, there is nine hypothesis and three hypotheses rejected, namely the price on satisfaction, the product quality on customer loyalty and the switching cost on customer loyalty. Based on the findings of this study conclude that the customer satisfaction is the dominant factor to build consumer loyalty by focus on service quality, product quality, and the switching cost.

#### **INTRODUCTION**

Competition is a phenomenon must be faced by companies both engaged in products and services. Answering this market phenomenon, companies keep improving their competence in service quality, product quality, price, and switching cost to achieve customers' satisfaction.

In the telecommunications market, many products with various advantages and more value-added offered its customers; so that it is difficult for companies to snatch market share from competitors. With such conditions, the tasks of marketers become complex because changes can occur at any time, such as changes in appetite, psychological aspects, social and cultural. On the other hand, marketers generally desire consumers they created can be maintained forever.

Darsono (2005) stated that loyalty is one of the elements to create enterprise value. Loyal customers have a lower propensity to perform switching brands and be a strong word of mouth. Dharmmesta (1999) suggested that the key in a competitive situation is the company's ability to increase customer loyalty. Customer loyalty will be the success key, not only in the short term but a sustainable competitive advantage. This is because customer loyalty has a strategic value for the company.

Loyalty has a relationship with profitability (Darsono, 2005). A loyal customer will reduce the search for new products or services. Aydin and Ozer (2005) stated that telecommunication companies lost 2% to 4% of their customers per month. Customers who are not loyal will reduce millions revenue and profits; thus, increasing customers loyalty is a must effort to maintain existing markets.

Customer loyalty in affective stage states that the antecedent of loyalty is satisfaction. Singh (2006) stated that satisfaction is a direct factor of customer loyalty. Meanwhile there is still disagreement on this point, for example Bloemer and Kasper (1995) which states that satisfaction has a positive association with loyalty but does not produce loyalty level to the same degree. Hellier, Geursen, Carr, and Rickard (2003) also stated that there is no relation between customers' satisfaction and customers' loyalty. Rowley and Dawes (2000) stated that the relationship between satisfaction and loyalty is not clear. Bernd and Patricia (1997) found that a number of customers expressing satisfaction still switch brands. This prompted to investigate more about switching variable in relation to the satisfaction of customer loyalty.

Other different opinions on the positive influence of service quality towards customers' satisfaction are Selnes (1993) and Sivadas and Baker-Prewitt (2000) who revealed that service quality affects satisfaction; However, Hellier et al. (2003) suggested that service quality has small influence on customer satisfaction. Selnes (1993) argued that service quality affects customer satisfaction and satisfaction affect loyalty and a desire not to switch brands. Griffin (1995) in Koskela (2002) stated that customer satisfaction is not enough, between 55-85% of customers who switch is a satisfied customer. Selnes (1993) said that product quality affects customer satisfaction. Additionally, Djati and Darmawan (2004) stated that price variables influence customer satisfaction.

Likewise related to brand switching costs carried by the customers with loyalty; switching costs are economic perception and psychological costs associated with changing from one provider to another provider (Jones et al, 2002 in Karsono, 2007). The switching costs is a barrier that hinder or prevent consumers in choosing (Burnham, Frels, & Mahajan, 2003).

Switching cost directly affects the sensitivity of consumers at price levels, so that affecting consumer loyalty (Bloemer & Kasper, 1995; Burnham et al., 2003). Changes in technology and differentiation strategy of the company lead switching become an important factor for consumer loyalty (Aydin & Ozer, 2005). Bloemer and Kasper (1995), explained that an industry with low switching costs tends to have less loyal customers than the service industry with high switching cost. Karsono (2007) differently explained that switching cost does not significantly affect customer loyalty, while according to Lee, Lee, and Feick (2001), for mobile phone users, switching cost also does not affect loyalty.

The unit of analysis is the telecommunications services especially mobile industry with the observation unit is the use of IM3 prepaid cards from Indosat. According Rukmana (2006), rapid telecommunications development is shown from the increasing number of telecommunication services users from 1991 to 2011, which users increased 5-fold in the world. The proportion number of users in Asia-Pacific compared to the total number of users also increased. This means that the growth of telecommunication services users in Asia-Pacific is

higher than other continents, while in Indonesia, there is a significant increase on the number of telecommunications services users from year to year.

The results of Top Brand Index fase I 2018 states there are three prepaid GSM cards brands as top category: Simpati by Telkomsel, IM3 by Indosat, XL Prepaid by XL. IM3 though belongs to top category, but still below Telkomsel with the acquisition of Top Brand Index by 14.4%. The difference percentage of 1.7% of Top Brand Index between XL Prepaid (12.7%) and IM3 (14.4%), has been a serious challenge for IM3 to rank first of Top Brand Index.

IM3 Indosat is chosen in this study because though the company is a large provider of mobile telecommunications services, but the market performance seems declining.

## **LITERATURE REVIEW**

### **Service Quality on Customers Satisfaction**

Hellier et al. (2003) states that service quality has only small influence on customer satisfaction. This is supported by Powpaka (1996) in Hellier et al. (2003) that the high standard of service quality is important but not sufficient to increase the overall customer satisfaction.

Other opinions said that the service quality should start from customers' needs and ends with customers' satisfaction and a positive perception of the service quality (Kotler, 2000). Parasuraman, Zeithaml, and Berry (1985) suggested customer satisfaction is the result of the buyer's perception on the service quality.

The relationship between service quality and satisfaction is extensively documented in the marketing literature, the relationship theoretically and empirically is positive as it has been investigated by Soderlund (1998). Theoretically when the services provided are able to meet or exceed consumers' expectations, they will be satisfied (Parasuraman, Zeithaml, and Berry, 1988).

Customer satisfaction is often defined in terms of gap paradigm between customers' perception of service quality and customers' expectations of service offered. So Voss, Parasuraman, and Grewal (1998) suggested that service quality inherent with customer satisfaction, in which the positive increase of service quality is a reflection of increased customer satisfaction.

Empirically, many studies with different background samples have proved that the service quality and customers' satisfaction is positive. Selnes (1993), Sivadas and Baker-Prewitt (2000) also proved the service quality affects satisfaction.

### **Product Quality on Customers Satisfaction**

Naser, Jamal, and Al-Khatib (1999) suggested that customers' satisfaction is highly dependent on the product quality level offered, but Naser et al. (1999) noted the lack of attention on the relationship between product quality and customer satisfaction in the context of a service company. Naser et al. (1999) showed that the product attributes influence customers' satisfaction. Selnes (1993) showed that the product performance as perceived by customers affects their satisfaction. The better the product quality, the higher the satisfaction.

### **Price on Customers Satisfaction**

Price is an extrinsic factor functioned as quality replacement when the customer does not have enough information about the intrinsic attributes, so that the customer uses price to estimate the quality. However, when the product quality is intrinsically known, this allegation is less convincing (Zeithaml, 1988). Chapman (1986), Mazumdar (1986), Monroe and Krishnan (1985) in Parasuraman et al. (1988) stated that price is the customers' sacrifice to obtain the desired product or service.

Zhang (2001) stated that the competition makes the business world satisfy the customers' needs at low prices. Abdul-Muhmin and Alhassan (2002) proved that the price variable influences customers' satisfaction. Bei and Chiao (2001) stated that from the customers' cognitive perception, price is something that should be given or sacrificed in obtaining a particular product or service. While the definition of consumer prices is the price they feel. Consumers think perceived price more meaningful than nominal price. Bei and Chiao (2001) in his research suggested that the perceived fairness of the price associated with customers' satisfaction. The higher the fairness of price perceived, the higher the satisfaction.

Devaraj, Matta, and Conlon (2001) stated that there is a positive relationship between price and satisfaction. Customers who pay more and get good benefits, will be satisfied.

### **Switching Cost on Customer Satisfaction**

Griffin (1995) in Koskela (2002) explained that while people said they were satisfied in a customer satisfaction survey, 85% of them said they would switch to another provider or supplier. They said that in a particular industry, 75% customers who switched to other service providers stated that they were satisfied or even very satisfied with the previous providers. Customers changed service providers because of price or new opportunities offered by competitors; or more simply because they want variety.

Post-purchase Cognitive Dissonance Theory (Aydin & Ozer, 2005) states that the customers who gather information to reduce anxiety about mistake in buying decision, would recast the past purchases experiences. In this process, if the customer switched, the comparison would be made between the new brand and the old brand. To lower the cognitive dissonance, customers tend to prefer brands that have been used and have been satisfied before.

### **Service Quality on Customers' Loyalty**

Zeithaml, Berry, and Parasuraman (1996) said service quality can directly affect customer loyalty and influence customer loyalty indirectly through satisfaction (Caruana, 2002). Service quality encourages customers to commit in a product / service of a company which leads to an increase in market share of a product. Service quality is crucial in retaining customers in a long time. Companies having superior service will be able to maximize their financial performance (Gilbert, Veloutsou, Goode, & Moutinho, 2004).

Improving service quality system would be much more effective for business continuity. According to the research results of the Wharton Business School, the efforts of these improvements will make consumers more loyal to the company (Rambat & Hamdani, 2006). The concept of service quality and loyalty are interconnected to one another. Theoretically, it provides guidance in this study, where the service quality affects the loyalty both directly and indirectly.

### **Product Quality on Customers' Loyalty**

Product quality is considered to have a strong impact on customer loyalty than satisfaction. The most interesting findings was the respondents in the study of Lee (1998) in Bei and Chiao (2001), who still visited a gas station where they were "not satisfied" with the services provided. This is because the gas station has good quality product. This explains that consumers are more concerned about the quality of petrol from service. So the product quality is considered having positive effects both directly and indirectly (through customer satisfaction) on customer loyalty.

### **Price on Customers' Loyalty**

Martín-Consuegra, Molina, and Esteban (2007) state that the price perceived positively is related to customer loyalty. This supports the hypothesis that the price can establish customer loyalty. The results support to the claim that certain prices are considered related to customer loyalty because the estimated parameters between the two constructions are positive and significant. Bei and Chiao (2001) found that prices had a significant relationship with customer loyalty, this finding is also supported by Virvalaite, Saladiene, and Skindaras (2009) who found that the price influences customer loyalty.

### **Switching Cost on Customers' Loyalty**

Aydin and Ozer (2005) finding in the Turkish GSM cellular industry shows that switching costs positively and directly affect loyalty, and also have the moderator effect on the variables of customer satisfaction and confidence in the loyalty. The statement was reinforced by Burnham et al. (2003) who found that the greater procedural switching cost, financial, and relational positively correlates with the increasing interest to continue using the current service provider.

Switching cost is a direct factor affecting the consumers' sensitivity on price level and thus affects consumer loyalty (Bloemer & Kasper, 1995; Burnham et al., 2003). Switching costs encourage consumers to recommend to other consumers (Lam, Shankar, Erramilli, and Murthy (2004). Changes in technology and the differentiation strategy of the company cause the switching cost be an important factor for consumer loyalty (Aydin & Ozer, 2005). Bloemer and Kasper (1995) stated that consumers in an industry with low switching cost tend to be less loyal than those in the service industry with high switching cost.

Fornell (1992) in Lee et al. (2001) said that the relationship between customer satisfaction and loyalty depends on factors such as market regulation, switching costs, brand equity and the existence of loyalty programs. Hauser et al (1994) in Lee et al. (2001) stated that the customers become less sensitive to the satisfaction because the switching cost increases. Lee et al. (2001) study informed that both aircraft industry and banking industry have high switching costs; while and supermarkets do not. The effects of switching cost on the relationship between satisfaction and loyalty depends also on the market structure. If the market is a monopoly, the effect of switching cost is small because the unsatisfied customers will not switch since there is no alternative. Switching cost becomes important if there are multiple providers. Switching costs play an important role by making high value to switch to another provider

(Lee et al., 2001), thereby increasing the switching cost will also increase customer loyalty.

### **Customer Satisfaction on Customers' Loyalty**

Customers who showed loyal attitude towards one of the products, prices and services has not been ascertained satisfied. Most loyal customers to the end of a particular event ever feel dissatisfied. Loyalty can build a sense of customers' satisfaction or not toward products, prices and service quality implemented by companies. A loyal customer who at one time feels dissatisfied, will give a negative response and action on product, price and service quality. Thus, loyalty can lead to satisfaction and dissatisfaction.

Furthermore, when satisfaction perceived can be found in all or any of the elements of the marketing mix and the service quality; then it will give positive feedback to remain loyal. Improving the service quality and rate one of the marketing mix is expected to foster customer loyalty.

Many researchers have conducted various studies on customer satisfaction. The relation between satisfaction and loyalty is not linear, as imagined by marketers. Rowley and Dawes (2000) explained the relationships between satisfaction and loyalty as not clear. Bernd and Patricia (1997) found that some customers who expressed their satisfaction were still brand-switching. Some dissatisfied customers, on the other hand, remained loyal. The same opinions uttered by Josee, Ruyter, and Peeters (1998) and Soderlund (1998) that satisfaction positively associates to loyalty, with a note that the increasing of satisfaction does not always result the increasing of loyalty at the same degree (Soderlund, 1998). Therefore, the relationship between satisfaction and loyalty is not linear, so that satisfied customers are still able to switch brands (Jones & Sasser, 1995). Oliva, Oliver, and MacMillan (1992) suggest that the relationship between customer satisfaction and customer loyalty is nonlinear.

Another study states that customer satisfaction positively influences customer loyalty, as Selnes (1993) said in 1062 companies consisted of telephone companies, insurers, universities and salmon suppliers

### **MATERIALS AND METHODS**

This study used quantitative descriptive highlighting on the influence between the variables of research and testing hypotheses formulated previously. The population (IM3 card users) in this study cannot be known certainly, so determining the sample size is guided by the views expressed by Hair, Black, Babin, Anderson, and Tatham (1998) who explained that the number of samples taken at least 5 times the number of parameters used in the study. Twenty-six parameters are used in the form of question items in the questionnaire, so that the minimum samples taken 130. Therefore, 160 IM3 users are taken as samples in Lampung Province.

Questionnaire validity testing was performed using Confirmatory Factor Analysis based on the Kaiser Meyer Olkin Measure of Sampling Adequacy Bartlett Test. While the reliability testing was done using Cronbach alpha. Furthermore, Structure Equation Model analysis was done to test the research hypotheses.

### **RESULTS AND DISCUSSIONS**

Table 1.

*Validity Testing Result*

Variable	KMO	p-value	Result
Service Quality	0.673	0.000	valid
Product Quality	0.771	0.000	valid
Price	0.556	0.001	valid
Switching Cost	0.764	0.000	valid
Customer Satisfaction	0.573	0.006	valid
Customer Loyalty	0.615	0.000	valid

Table 2.

*Reliability Testing Result*

Variable	No of Items	Cronbach's Alpha	Result
Service Quality	5	0.683	Reliable
Product Quality	6	0.754	Reliable
Price	3	0.638	Reliable
Switching Cost	5	0.723	Reliable
Customer Satisfaction	3	0.601	Reliable
Customer Loyalty	4	0.635	Reliable

Table 3.

*CFA Measurement on Service Quality*

No	Indicator	Coefficient Estimation (Standardized)	T-Value	Sig
1	KPL1	0.24	5.57	Significant
2	KPL2	0.37	7.82	Significant
3	KPL3	0.33	6.75	Significant
4	KPL4	0.39	7.95	Significant
5	KPL5	0.29	6.29	Significant

Table 4.

*CFA Measurement on Product Quality*

No	Indicator	Coefficient Estimation (Standardized)	T-Value	Sig
1	KPD1	0.32	7.32	Significant
2	KPD2	0.44	8.96	Significant
3	KPD3	0.33	7.32	Significant
4	KPD4	0.39	8.25	Significant
5	KPD5	0.32	7.30	Significant
6	KPD6	0.33	6.99	Significant

Table 5.

*CFA Measurement on Price*

No	Indicator	Coefficient Estimation (Standardized)	T-Value	Sig
1	H1	0.32	5.95	Significant
2	H2	0.28	5.71	Significant
3	H3	0.25	5.27	Significant

Table 6.

*CFA Measurement on Switching Cost*

No	Indicator	Coefficient Estimation (Standardized)	T-Value	Sig
1	SC1	0.32	6.63	Significant
2	SC2	0.40	7.79	Significant
3	SC3	0.38	7.85	Significant

4	SC4	0.43	8.74	Significant
5	SC5	0.29	6.68	Significant

Table 7.

*CFA Measurement on Satisfaction*

No	Indicator	Coefficient Estimation (Standardized)	T-Value	Sig
1	K1	0.30	8.45	Significant
2	K2	0.31	6.26	Significant
3	K3	0.22	5.63	Significant

Table 8.

*CFA Measurement on Loyalty*

No	Indicator	Coefficient Estimation (Standardized)	T-Value	Sig
1	L1	0.38	8.52	Significant
2	L2	0.32	6.68	Significant
3	L3	0.32	6.32	Significant
4	L4	0.31	7.77	Significant

Based on table 1 – 8, the result of validity and reliability test that all indicator has been valid dan reliabel. Furthermore, the confirmatory factor analysis (CFA) test that all indicators is significant. It means that all indicator can used to measure model.

Table 9.

*Normality Test*

	Descriptive Statistics			
	Skewness		Kurtosis	
	Statistic	Std. Error	Statistic	Std. Error
Unstandardized Residual	-.351	.192	.483	.381

Based on normality test, it show that skewness ratio and kurtosis ratio is in range -2 until 2. It means the data distribution is normal, so it is feasible to proceed in testing the hypothesis.



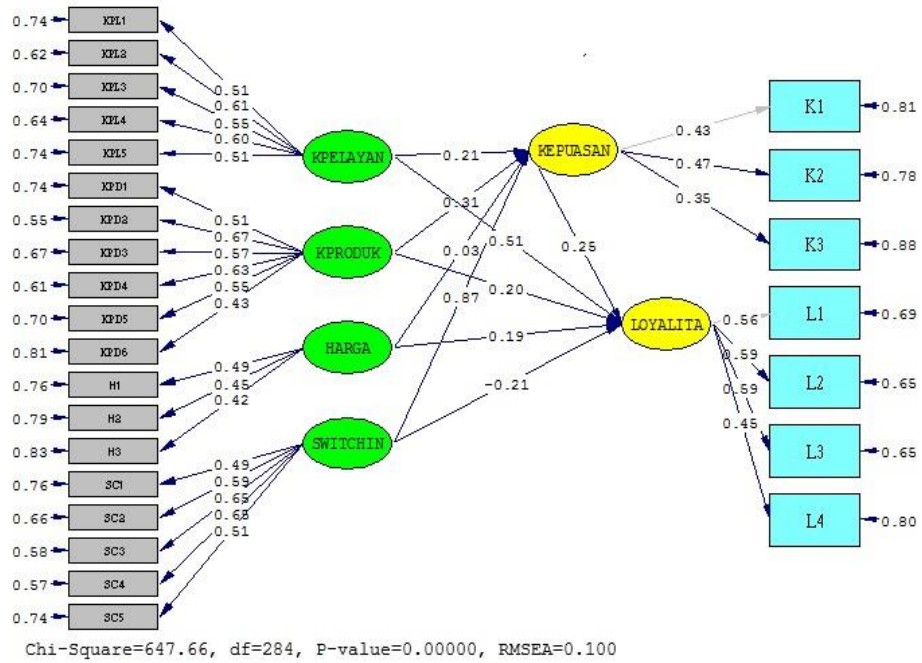

**Matches Test of Structural Model**

Figure 1. Estimation of Full Structural Model – Preliminary

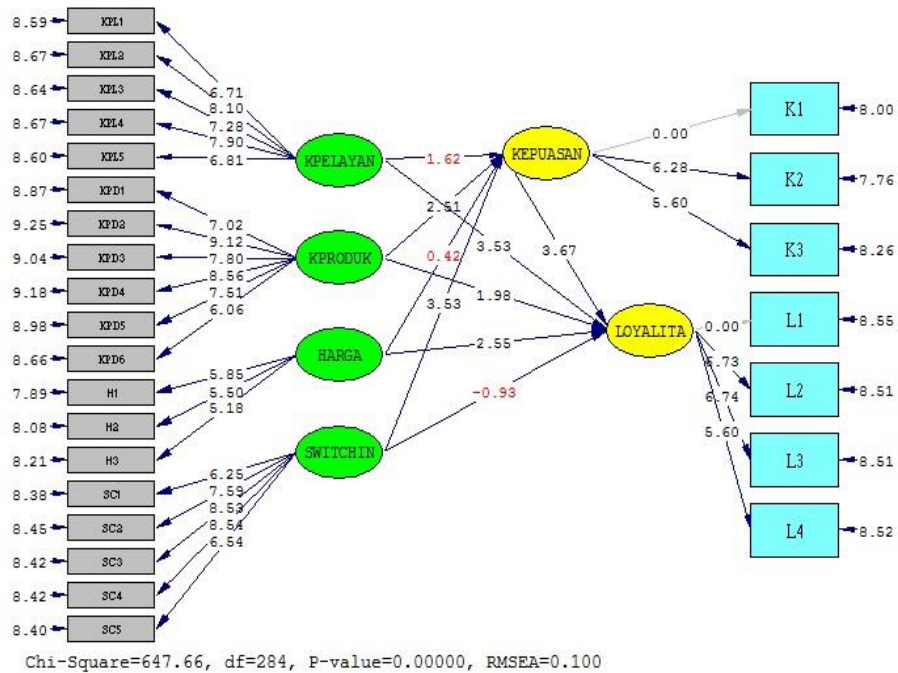

Figure 2. T-values of Full Structural Model – Preliminary

Evaluation of goodness-of-fit value of structural models that have been carried out in Figures 1 and 2 above, are presented in the following table:

Table 10.

*Goodness of fit Structural Model Index*

Goodness of Fit Statistics	Model Result	Criteria
X <sup>2</sup> /df (P)	647.66 (0.000)	Less Good

<b>NFI; NNFI</b>	0.89; 0.93	Less Good
<b>CFI; IFI</b>	0.94; 0.94	Good
<b>RMSEA</b>	0.100	Less Good
<b>GFI; AGFI</b>	0.72; 0.66	Less Good

The structure model has not shown the best result, so it needs to be improved model by adding the covariate error in model.

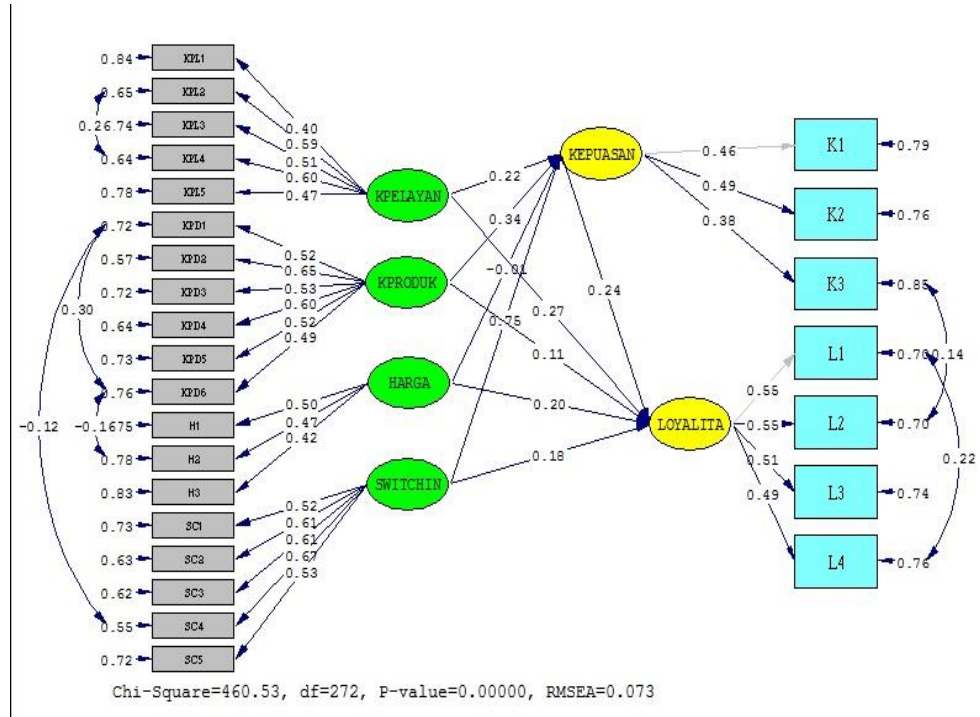

Figure 3. Estimation of Full Stuctural Model – After Modification

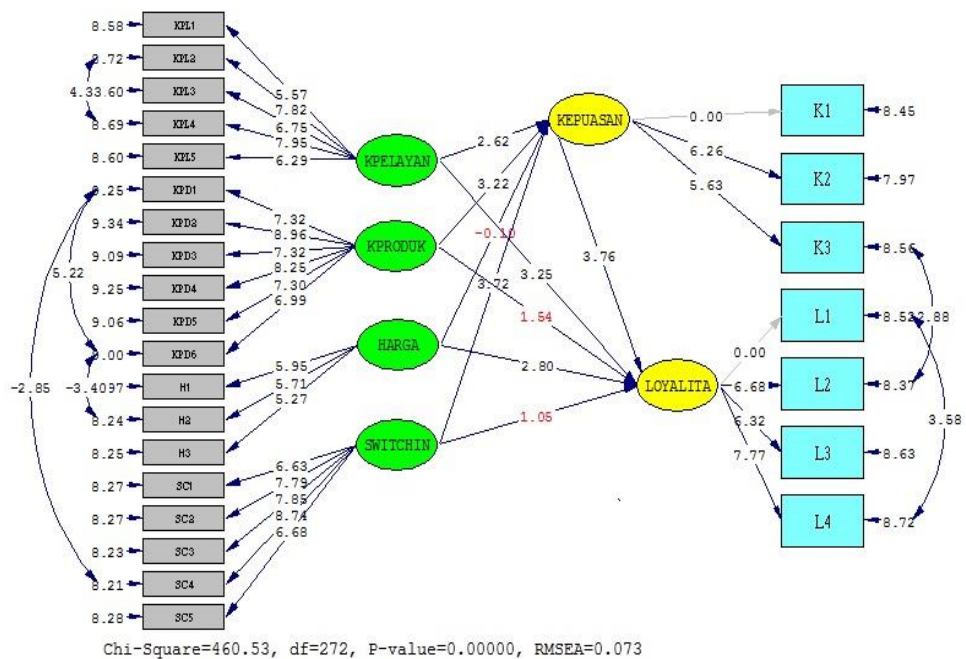

Figure 4. T-values of Full Structural Model – After Modification

Having modified the model and evaluated the value of goodness of fit of structural models carried out in figure 3 and 4 above, the summary are presented in the following table:

Table 11.

*Goodness of fit Structural Model Index*

<b>Goodness of Fit Statistics</b>	<b>Model Result</b>	<b>Criteria</b>
<b>Chi Square (P)</b>	435.53 (0.000)	Good
<b>NFI; NNFI</b>	0.89; 0.93	Good
<b>CFI; IFI</b>	0.94; 0.94	Good
<b>RMSEA</b>	0.100	Good
<b>GFI; AGFI</b>	0.72; 0.66	Less Good

As seen on the table 11, the value of suitability model is better than the previous one. The decreasing value of Chi Square from 647.66 to 435.53 with a probability of 0.000 showed better results than previously though the probability is still under 0.05; so that the overall model is expressed as goodfit. Although the values of GFI and AGFI are not suitable to criteria but the value of other models have met all the goodfit-criteria. So the model does not need another modification and can be analyzed.

**Hypothesis Testing**

Table 12.

*Hypothesis Testing Result*

<b>Path</b>	<b>Regression Coefficient</b>	<b>T - Value</b>	<b>Conclusion</b>	<b>Result</b>
<b>Service Quality → Satisfaction</b>	0.22	2.62	Sig.	H <sub>1</sub> Accepted
<b>Product Quality → Satisfaction</b>	0.34	3.22	Sig.	H <sub>2</sub> Accepted
<b>Price → Satisfaction</b>	-0.0057	-0.10	Not Sig	H <sub>3</sub> Rejected
<b>Switching Cost → Satisfaction</b>	0.75	3.72	Sig.	H <sub>4</sub> Accepted
<b>Service Quality → Loyalty</b>	0.27	3.25	Sig.	H <sub>5</sub> Accepted
<b>Product Quality → Loyalty</b>	0.11	1.54	Not Sig	H <sub>6</sub> Rejected
<b>Price → Loyalty</b>	0.20	2.80	Sig.	H <sub>7</sub> Accepted
<b>Switching Cost → Loyalty</b>	0.18	1.05	Not Sig	H <sub>8</sub> Rejected
<b>Satisfaction → Loyalty</b>	0.24	3.76	Sig.	H <sub>9</sub> Accepted

From the structural model, service quality influences customer satisfaction with the coefficient value 0.22 and t-value 2.62. It means hypothesis is accepted. Product quality influences customer satisfaction with the coefficient value 0.34 and t-value 3.22. It mean hypothesis is accepted. Price no effect to customer satisfaction so hypothesis is rejected. Switching cost influences customer satisfaction with the coefficient value 0.75 and t-value 3.72. Service quality influences customer loyalty with the coefficient

value 0.27 and t-value 3.25. Product quality no effect to customer loyalty so hypothesis is rejected. Price influences customer loyalty with the coefficient value 0.20 and t-value 2.80. Switching cost no effect to customer loyalty. The last, satisfaction influences customer loyalty with the coefficient value 0.24 and t-value 3.76. It means six the inter-construct relationships are significant because the t-value is bigger than the cut off 1.96, and the rest is not significant.

## CONCLUSIONS

The results of this study prove that service quality empirically affects the customer satisfaction. This shows the importance of IM3 service quality in increasing customer satisfaction.

It is proven empirically that the product quality affects positively and significantly on customer satisfaction. The evidence shows that customer satisfaction depends heavily on the product quality offered. Thus, the company should be able to produce quality products that fit the needs, desires and expectations of customers, in order to maintain the satisfaction level of IM3 customers.

It is empirically proven that the price does not affect the customer's satisfaction. This indicates that the price of IM3 cards as marketing variables do not have a role in increasing customer satisfaction. Then, it is necessary for the company to pay attention to the price set to match the qualities of product and services offered.

The results of this study prove that the switching cost affects customer satisfaction. This needs to be the basis of the company's policy to increase the switching cost by prioritizing the customer satisfaction.

The study also results that service quality affects customer loyalty. This shows the importance of service quality in forming the IM3 card customers' loyalty

It is also proven empirically that the product quality does not affect the customer loyalty. The evidence shows that customer satisfaction does not depend on the product quality. Thus, in order to build IM3 customers' loyalty, the company must be able to produce a quality product that fits the needs, desires, and expectations of customers

That the price affects customer loyalty is proven empirically. This indicates that the IM3 card price as marketing variables have a role in shaping customer loyalty. Therefore, the company should pay attention on the price set to match the qualities of products and services offered.

The switching cost does not affect customer satisfaction has been proven in this study. This needs to be the basis of the company's policy to increase the switching cost by prioritizing customer loyalty

Empirically proven that customer satisfaction affects positively and significantly the customer loyalty. This indicates that satisfied customers will be loyal to the product and the service. Then the policies established by the company need to be always customer-satisfaction oriented.

## REFERENCES

- Abdul-Muhmin., & Alhassan, G. (2002). Effects of suppliers' marketing program variables on industrial buyers' relationship satisfaction and commitment. *Journal of Business & Industrial Marketing*, 17(7), 637-651.
- Aydin, S., & Ozer, G. (2005). The analysis of antecedents of customer loyalty in the Turkish mobile telecommunication market. *European Journal of Marketing*, 39(7/8), 910-925. doi: doi:10.1108/03090560510601833
- Bei, L.-T., & Chiao, Y.-C. (2001). An integrated model for the effects of perceived product, perceived service quality, and perceived price fairness on consumer satisfaction and loyalty. *Journal of consumer satisfaction, dissatisfaction and complaining behavior*, 14, 125.
- Bernd, S., & Patricia, N. (1997). The qualitative satisfaction model. *International Journal of Service Industry Management*, 8(3), 236-249. doi: doi:10.1108/09564239710185424
- Bloemer, J., M M., & Kasper, H. D. P. (1995). The complex relationship between consumer satisfaction and brand loyalty. *Journal of Economic Psychology*, 16(2), 311-329.
- Burnham, T., A, Frels, J., K, & Mahajan, V. (2003). Consumer switching costs: A typology, antecedents, and consequences. *Journal of the Academy of Marketing Science*, 31(2), 109-126.
- Caruana, A. (2002). Service loyalty: The effects of service quality and the mediating role of customer satisfaction. *European Journal of Marketing*, 36(7/8), 811-828. doi: doi:10.1108/03090560210430818
- Darsono, L., I. (2005). Loyalty & Disloyalty: Sebuah Pandangan Komprehensif Dalam Analisa Loyalitas Pelanggan. *Jurnal Administrasi dan Bisnis*, 4.
- Devaraj, S., Matta, K., F., & Conlon, E. (2001). Product and service quality: the antecedents of customer loyalty in the automotive industry. *Production and Operations Management*, 10(4), 424-439.
- Dharmmesta, B. S. (1999). Loyalitas Pelanggan: Sebuah Kaman Konseptual Sebagai Panduan Bagi Peneliti. *Jurnal Ekonomi dan Bisnis Indonesia*, 14(1999).
- Djati, S., P., & Darmawan, D. (2004). Pengaruh kesan kualitas layanan, harga, dan kepuasan mahasiswa PTS terhadap minat mereferensikan kampusnya. *Widya Journal of Management and Accounting*, 4(2).
- Gilbert, G. R., Veloutsou, C., Goode, M. M. H., & Moutinho, L. (2004). Measuring customer satisfaction in the fast food industry: a cross-national approach. *Journal of Services Marketing*, 18(5), 371-383. doi: doi:10.1108/08876040410548294
- Hair, J., F, Black, W., C, Babin, B., J, Anderson, R., E, & Tatham, R., L. (1998). *Multivariate data analysis* (Vol. 5). Upper Saddle River, NJ: Prentice hall.
- Hellier, P., K., Geursen, G., M., Carr, R., A., & Rickard, J., A. (2003). Customer repurchase intention: A general structural equation

- model. *European Journal of Marketing*, 37(11/12), 1762-1800. doi: doi:10.1108/03090560310495456
- Jones, T., O., & Sasser, W., Earl. (1995). Why satisfied customers defect. *Harvard business review*, 73(6), 88-&.
- Josee, B., Ruyter, K., De, & Peeters, P. (1998). Investigating drivers of bank loyalty: the complex relationship between image, service quality and satisfaction. *International Journal of Bank Marketing*, 16(7), 276-286.
- Karsono. (2007). Peran Variabel Citra Perusahaan, Kepercayaan dan Biaya Perpindahan yang memediasi Pengaruh Kualitas Pelayanan Terhadap Loyalitas pelanggan Pada PT Indosat. *Jurnal Bisnis dan Manajemen*, 7, 93-110.
- Koskela, H. (2002). *Customer satisfaction and loyalty in after sales service: Modes of care in telecommunications systems delivery*. Helsinki University of Technology.
- Kotler, P. (2000). *Marketing Management*. Prentice Hall.
- Lam, S. Y., Shankar, V., Erramilli, M. K., & Murthy, B. (2004). Customer Value, Satisfaction, Loyalty, and Switching Costs: An Illustration From a Business-to-Business Service Context. *Journal of the Academy of Marketing Science*, 32(3), 293-311. doi: 10.1177/0092070304263330
- Lee, J., Lee, J., & Feick, L. (2001). The impact of switching costs on the customer satisfaction-loyalty link: mobile phone service in France. *Journal of Services Marketing*, 15(1), 35-48. doi: doi:10.1108/08876040110381463
- Martín-Consuegra, D., Molina, A., & Esteban, Á. (2007). An integrated model of price, satisfaction and loyalty: an empirical analysis in the service sector. *Journal of Product & Brand Management*, 16(7), 459-468. doi: doi:10.1108/10610420710834913
- Naser, K., Jamal, A., & Al-Khatib, K. (1999). Islamic banking: a study of customer satisfaction and preferences in Jordan. *International Journal of Bank Marketing*, 17(3), 135-151.
- Oliva, T., A, Oliver, R., L, & MacMillan, I., C. (1992). A catastrophe model for developing service satisfaction strategies. *the Journal of Marketing*, 83-95.
- Parasuraman, A., Zeithaml, V. A., & Berry, L. L. (1985). A Conceptual Model of Service Quality and Its Implications for Future Research. *Journal of Marketing*, 49(4), 41-50. doi: 10.2307/1251430
- Parasuraman, A., Zeithaml, V., A., & Berry, L., L. (1988). Servqual: A multiple-item scale for measuring consumer perceptions of Service Quality. *Journal of retailing*, 64(1), 12.
- Rambat, L., & Hamdani, A. (2006). *Manajemen Pemasaran Jasa*. Edisi. Kedua. Jakarta: Salemba Empat.
- Rowley, J., & Dawes, J. (2000). Disloyalty: a closer look at non-loyals. *Journal of Consumer Marketing*, 17(6), 538-547. doi: doi:10.1108/07363760010349948
- Rukmana, R. A. (2006). Analisis Tuntutan Pelanggan, Kinerja Bauran Pemasaran Jasa, Nilai Pelanggan dan Penggunaan Jasa Telekomunikasi. *Usahawan*, XXXV(3).

- Selnes, F. (1993). An examination of the effect of product performance on brand reputation, satisfaction and loyalty. *European Journal of Marketing*, 27(9), 19-35.
- Singh, H. (2006). The importance of customer satisfaction in relation to customer loyalty and retention. *Academy of Marketing Science*, 60, 193-225.
- Sivadas, E., & Baker-Prewitt, J. L. (2000). An examination of the relationship between service quality, customer satisfaction, and store loyalty. *International Journal of Retail & Distribution Management*, 28(2), 73-82. doi:10.1108/09590550010315223
- Soderlund, M. (1998). Customer satisfaction and its consequences on customer behaviour revisited: The impact of different levels of satisfaction on word-of-mouth, feedback to the supplier and loyalty. *International Journal of Service Industry Management*, 9(2), 169-188.
- Virvalaite, R., Saladiene, V., & Skindaras, D. (2009). The relationship between price and loyalty in services industry. *Engineering Economics*, 63(4).
- Voss, G. B., Parasuraman, A., & Grewal, D. (1998). The roles of price, performance, and expectations in determining satisfaction in service exchanges. *the Journal of Marketing*, 46-61.
- Zeithaml, V. A. (1988). Consumer perceptions of price, quality, and value: A means-end model and synthesis of evidence. *Journal of Marketing*, 52, 2-22.
- Zeithaml, V., A., Berry, L., L., & Parasuraman, A. (1996). The behavioral consequences of service quality. *The Journal of Marketing*, 60(2), 31-46.
- Zhang, Q. (2001). Quality dimensions, perspectives and practices: A mapping analysis. *International Journal of Quality & Reliability Management*, 18(7), 708-722. doi:10.1108/EUM0000000005777